



MICROCHIP

**Curiosity High Pin Count (HPC)
Development Board
User's Guide**

Note the following details of the code protection feature on Microchip devices:

- Microchip products meet the specification contained in their particular Microchip Data Sheet.
- Microchip believes that its family of products is one of the most secure families of its kind on the market today, when used in the intended manner and under normal conditions.
- There are dishonest and possibly illegal methods used to breach the code protection feature. All of these methods, to our knowledge, require using the Microchip products in a manner outside the operating specifications contained in Microchip's Data Sheets. Most likely, the person doing so is engaged in theft of intellectual property.
- Microchip is willing to work with the customer who is concerned about the integrity of their code.
- Neither Microchip nor any other semiconductor manufacturer can guarantee the security of their code. Code protection does not mean that we are guaranteeing the product as "unbreakable."

Code protection is constantly evolving. We at Microchip are committed to continuously improving the code protection features of our products. Attempts to break Microchip's code protection feature may be a violation of the Digital Millennium Copyright Act. If such acts allow unauthorized access to your software or other copyrighted work, you may have a right to sue for relief under that Act.

Information contained in this publication regarding device applications and the like is provided only for your convenience and may be superseded by updates. It is your responsibility to ensure that your application meets with your specifications. MICROCHIP MAKES NO REPRESENTATIONS OR WARRANTIES OF ANY KIND WHETHER EXPRESS OR IMPLIED, WRITTEN OR ORAL, STATUTORY OR OTHERWISE, RELATED TO THE INFORMATION, INCLUDING BUT NOT LIMITED TO ITS CONDITION, QUALITY, PERFORMANCE, MERCHANTABILITY OR FITNESS FOR PURPOSE. Microchip disclaims all liability arising from this information and its use. Use of Microchip devices in life support and/or safety applications is entirely at the buyer's risk, and the buyer agrees to defend, indemnify and hold harmless Microchip from any and all damages, claims, suits, or expenses resulting from such use. No licenses are conveyed, implicitly or otherwise, under any Microchip intellectual property rights unless otherwise stated.

Trademarks

The Microchip name and logo, the Microchip logo, Adaptec, AnyRate, AVR, AVR logo, AVR Freaks, BesTime, BitCloud, chipKIT, chipKIT logo, CryptoMemory, CryptoRF, dsPIC, FlashFlex, flexPWR, HELDO, IGLOO, JukeBlox, KeeLoq, Klear, LANCheck, LinkMD, maXStylus, maXTouch, MediaLB, megaAVR, Microsemi, Microsemi logo, MOST, MOST logo, MPLAB, OptoLyzer, PackeTime, PIC, picoPower, PICSTART, PIC32 logo, PolarFire, Prochip Designer, QTouch, SAM-BA, SenGenuity, SpyNIC, SST, SST Logo, SuperFlash, Symmetricom, SyncServer, Tachyon, TempTracker, TimeSource, tinyAVR, UNI/O, Vectron, and XMEGA are registered trademarks of Microchip Technology Incorporated in the U.S.A. and other countries.

APT, ClockWorks, The Embedded Control Solutions Company, EtherSynch, FlashTec, Hyper Speed Control, HyperLight Load, IntelliMOS, Libero, motorBench, mTouch, Powermite 3, Precision Edge, ProASIC, ProASIC Plus, ProASIC Plus logo, Quiet-Wire, SmartFusion, SyncWorld, Temux, TimeCesium, TimeHub, TimePictra, TimeProvider, Vite, WinPath, and ZL are registered trademarks of Microchip Technology Incorporated in the U.S.A.

Adjacent Key Suppression, AKS, Analog-for-the-Digital Age, Any Capacitor, AnyIn, AnyOut, BlueSky, BodyCom, CodeGuard, CryptoAuthentication, CryptoAutomotive, CryptoCompanion, CryptoController, dsPICDEM, dsPICDEM.net, Dynamic Average Matching, DAM, ECAN, EtherGREEN, In-Circuit Serial Programming, ICSP, INICnet, Inter-Chip Connectivity, JitterBlocker, KlearNet, KlearNet logo, memBrain, Mindi, MiWi, MPASM, MPF, MPLAB Certified logo, MPLIB, MPLINK, MultiTRAK, NetDetach, Omniscient Code Generation, PICDEM, PICDEM.net, PICKit, PICtail, PowerSmart, PureSilicon, QMatrix, REAL ICE, Ripple Blocker, SAM-ICE, Serial Quad I/O, SMART-I.S., SQR, SuperSwitcher, SuperSwitcher II, Total Endurance, TSHARC, USBCheck, VariSense, ViewSpan, WiperLock, Wireless DNA, and ZENA are trademarks of Microchip Technology Incorporated in the U.S.A. and other countries.

SQTP is a service mark of Microchip Technology Incorporated in the U.S.A.

The Adaptec logo, Frequency on Demand, Silicon Storage Technology, and Symmcom are registered trademarks of Microchip Technology Inc. in other countries.

GestIC is a registered trademark of Microchip Technology Germany II GmbH & Co. KG, a subsidiary of Microchip Technology Inc., in other countries.

All other trademarks mentioned herein are property of their respective companies.

© 2016-2020, Microchip Technology Incorporated, All Rights Reserved.

ISBN: 978-1-5224-5842-5

For information regarding Microchip's Quality Management Systems, please visit www.microchip.com/quality.



CURIOSITY HIGH PIN COUNT DEVELOPMENT BOARD USER'S GUIDE

Table of Contents

Preface	4
Chapter 1. Introduction to Curiosity High Pin Count (HPC)	
1.1 Curiosity High Pin Count (HPC) Development Board Kit Contents	8
Chapter 2. Getting Started	
2.1 Programming the Curiosity HPC Development Board	11
2.1.1 Programming Using MPLAB X IDE	11
Chapter 3. Troubleshooting	
3.1 The MCU Will Not Program Using The PKOB	15
3.2 The MPLAB PICKit™ 4 On-Board (PKOB4) Does Not Perform	15
Appendix A. Schematic	
A.1 Curiosity HPC Development Board Schematic	16
Appendix B. General Notes	
B.1 mikroBus™ Clicks	21
B.2 Solder Blob Jumper	21
Worldwide Sales and Service	22



CURIOSITY HIGH PIN COUNT DEVELOPMENT BOARD USER'S GUIDE

Preface

NOTICE TO CUSTOMERS

All documentation becomes dated, and this manual is no exception. Microchip tools and documentation are constantly evolving to meet customer needs, so some actual dialogs and/or tool descriptions may differ from those in this document. Please refer to our website (www.microchip.com) to obtain the latest documentation available.

Documents are identified with a “DS” number. This number is located on the bottom of each page, in front of the page number. The numbering convention for the DS number is “DSXXXXXA”, where “XXXXX” is the document number and “A” is the revision level of the document.

For the most up-to-date information on development tools, see the MPLAB® IDE online help. Select the Help menu, and then Topics to open a list of available online help files.

INTRODUCTION

This chapter contains general information that will be useful to know before using the Curiosity HPC Development Board. Items discussed in this chapter include:

- Document Layout
- Conventions Used in this Guide
- Recommended Reading
- The Microchip Website
- Development Systems Customer Change Notification Service
- Customer Support
- Revision History

DOCUMENT LAYOUT

This document describes how to use the Curiosity HPC Development Board as a development tool to emulate and debug firmware on a target board. The document is organized as follows:

- **Chapter 1. “Introduction to Curiosity High Pin Count (HPC)”** – This chapter contains general information regarding the Curiosity HPC Development Board kit contents, layout and power source.
- **Chapter 2. “Getting Started”** – This chapter offers information on how to program the Curiosity HPC Development Board.
- **Chapter 3. “Troubleshooting”** – Consult this chapter for troubleshooting information.
- **Appendix A. “Schematic”** – This appendix lists the Curiosity HPC Development Board schematic.
- **Appendix B. “General Notes”** – Refer to this appendix for general notes on using the Click module sockets and the solder blob jumpers.

Curiosity High Pin Count Development Board User's Guide

CONVENTIONS USED IN THIS GUIDE

This manual uses the following documentation conventions:

DOCUMENT CONVENTIONS

Description	Represents	Examples
Arial font:		
Italic characters	Referenced books	<i>MPLAB IDE User's Guide</i>
	Emphasized text	...is the <i>only</i> compiler...
Initial caps	A window	the Output window
	A dialog	the Settings dialog
	A menu selection	select Enable Programmer
Quotes	A field name in a window or dialog	"Save project before build"
Underlined, italic text with right angle bracket	A menu path	<u><i>File>Save</i></u>
Bold characters	A dialog button	Click OK
	A tab	Click the Power tab
N'Rnnnn	A number in verilog format, where N is the total number of digits, R is the radix and n is a digit.	4'b0010, 2'hF1
Text in angle brackets < >	A key on the keyboard	Press <Enter>, <F1>
Courier New font:		
Plain Courier New	Sample source code	#define START
	Filenames	autoexec.bat
	File paths	c:\mcc18\h
	Keywords	_asm, _endasm, static
	Command-line options	-Opa+, -Opa-
	Bit values	0, 1
	Constants	0xFF, 'A'
Italic Courier New	A variable argument	<i>file.o</i> , where <i>file</i> can be any valid filename
Square brackets []	Optional arguments	mcc18 [options] <i>file</i> [options]
Curly brackets and pipe character: { }	Choice of mutually exclusive arguments; an OR selection	errorlevel {0 1}
Ellipses...	Replaces repeated text	var_name [, var_name...]
	Represents code supplied by user	void main (void) { ... }

RECOMMENDED READING

This user's guide describes how to use the Curiosity HPC Development Board. For the latest information on using other tools, refer to the MPLAB® X IDE home page: www.microchip.com/mplab/mplab-x-ide. This resource page contains updated documentation, downloads and links to other MPLAB X compatible tools, plug-ins and much more.

THE MICROCHIP WEBSITE

Microchip provides online support via our website at www.microchip.com. This website is used as a means to make files and information easily available to customers. Accessible by using your favorite Internet browser, the website contains the following information:

- **Product Support** – Data sheets and errata, application notes, sample programs and labs, design resources, user's guides and hardware support documents, latest software releases and archived software
Curiosity Development Board-specific product support can be accessed via our website at www.microchip.com/promo/curiosity-development-boards.
- **General Technical Support** – Frequently Asked Questions (FAQs), technical support requests, online discussion groups, Microchip consultant program member listing
- **Business of Microchip** – Product selector and ordering guides, latest Microchip press releases, listing of seminars and events, listings of Microchip sales offices, distributors and factory representatives

DEVELOPMENT SYSTEMS CUSTOMER CHANGE NOTIFICATION SERVICE

Microchip's customer notification service helps keep customers current on Microchip products. Subscribers will receive e-mail notification whenever there are changes, updates, revisions or errata related to a specified product family or development tool of interest.

To register, access the Microchip website at www.microchip.com, click on Customer Change Notification and follow the registration instructions.

The Development Systems product group categories are:

- **Compilers** – The latest information on Microchip C compilers, assemblers, linkers and other language tools. These include all MPLAB C compilers; all MPLAB assemblers (including MPASM™ assembler); all MPLAB linkers (including MPLINK™ object linker); and all MPLAB librarians (including MPLIB™ object librarian).
- **Emulators** – The latest information on Microchip in-circuit emulators. This includes the MPLAB REAL ICE™ and MPLAB ICE 2000 in-circuit emulators.
- **In-Circuit Debuggers** – The latest information on the Microchip in-circuit debuggers. This includes MPLAB ICD 3 in-circuit debuggers and PICKit™ 3 debug express.
- **MPLAB IDE** – The latest information on Microchip MPLAB IDE, the Windows® Integrated Development Environment for development systems tools. This list is focused on the MPLAB IDE, MPLAB IDE Project Manager, MPLAB Editor and MPLAB SIM simulator, as well as general editing and debugging features.
- **Programmers** – The latest information on Microchip programmers. These include production programmers such as MPLAB REAL ICE in-circuit emulator, MPLAB ICD 3 in-circuit debugger and MPLAB PM3 device programmers. Also included are nonproduction development programmers such as PICSTART® Plus and PICKit 2 and 3.

CUSTOMER SUPPORT

Users of Microchip products can receive assistance through several channels:

- Distributor or Representative
- Local Sales Office
- Field Application Engineer (FAE)
- Technical Support

Customers should contact their distributor, representative or field application engineer (FAE) for support. Local sales offices are also available to help customers.

Technical support is available through the website at:

www.microchip.com/support.

REVISION HISTORY

Revision C (March 2020)

Updated Appendix A and Figure 1-1.

Added Section 3.2.

Other minor editorial updates.

Revision B (August 2018)

Updated Appendix B.

Other minor editorial updates.

Revision A (July 2016)

Initial release of this document.



CURIOSITY HIGH PIN COUNT DEVELOPMENT BOARD USER'S GUIDE

Chapter 1. Introduction to Curiosity High Pin Count (HPC)

The Curiosity High Pin Count (HPC) Development Board supports Microchip's 28 and 40-pin 8-bit PIC[®] MCUs. Two unique PDIP sockets are surrounded by dual-row expansion headers, which allow for connectivity to all pins on the PIC MCUs. Programming/debugging is accomplished through the PICKit[™] On-Board (PKOB), eliminating the need for an external programming/debugging tool. The development board includes a set of four indication LEDs, a potentiometer, and push-button switches. Additionally, the Curiosity HPC Board integrates two MikroElektronika mikroBUS[™] sockets, which accommodate a variety of plug-in Click[™] Board modules that can be used for application development.

1.1 CURIOSITY HIGH PIN COUNT (HPC) DEVELOPMENT BOARD KIT CONTENTS

The Curiosity High Pin Count (HPC) Development Board kit contains the following:

- Curiosity High Pin Count (HPC) Development Board
- Quick Start Guide
- PIC18F47Q10 MCU

Introduction to Curiosity High Pin Count (HPC)

FIGURE 1-2: HPC DEVELOPMENT BOARD REV 2

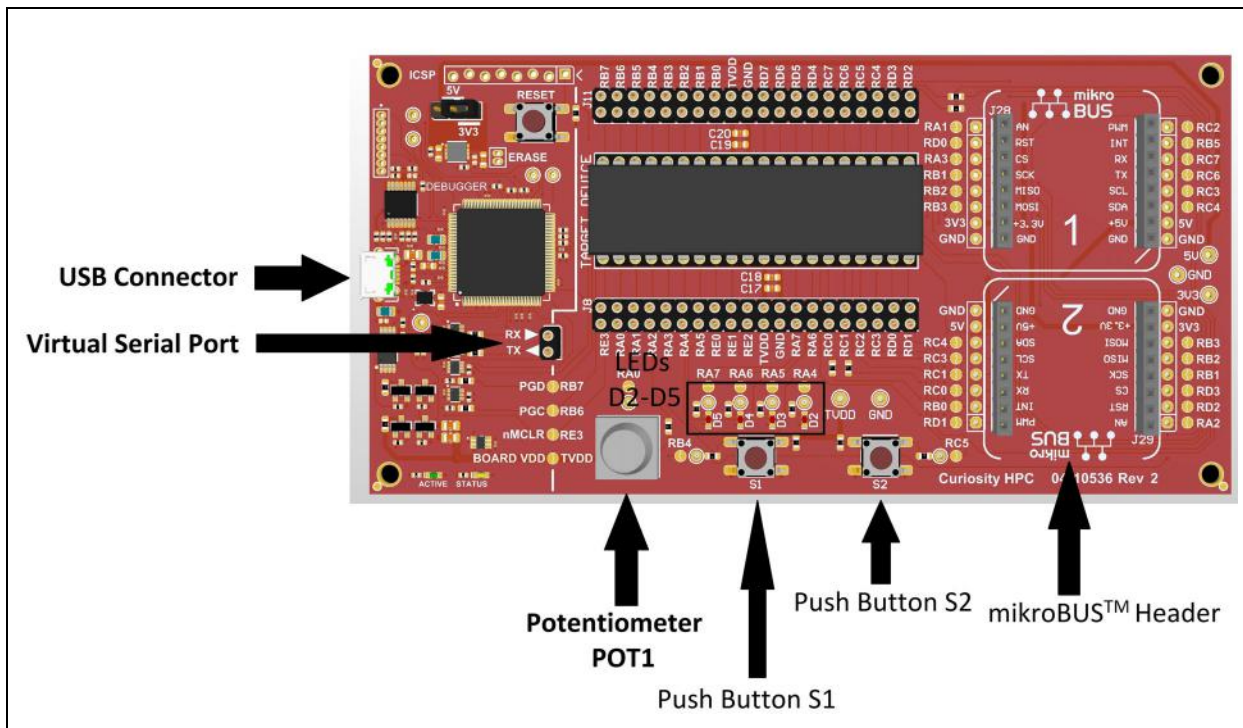

Chapter 2. Getting Started

The Curiosity HPC Development Board can be used with either MPLAB® X Integrated Development Environment (IDE, version 3.0 or higher) or MPLAB® Xpress IDE; both IDEs are available for free at www.microchip.com.

The Curiosity HPC Development Board contains a PICkit On-Board (PKOB) which allows for both low-voltage programming and low-voltage in-circuit debugging for all supported devices. When used with the MPLAB IDE, in-circuit debugging allows the user to run, modify, and troubleshoot their custom software and hardware quickly, without the need for additional debugging tools.

2.1 PROGRAMMING THE CURIOSITY HPC DEVELOPMENT BOARD

Programming the Curiosity HPC Development Board can be accomplished through one of the two following ways: either through MPLAB X IDE (version 3.30 or higher for Rev 1 and version 5.20 or higher for Rev 2), or through MPLAB Xpress.

<p>Note: The Curiosity HPC Board must be programmed using Low-Voltage Programming (LVP). The LVP bit of the Configuration Word(s) must be set (LVP = ON or '1').</p>

2.1.1 Programming Using MPLAB X IDE

1. Connect the Curiosity HPC Board to the computer using the on-board micro-USB connector.
2. Open MPLAB X IDE and either create a new project or open an existing one.
3. Click on the **Project Properties** icon located in the project's Dashboard window (as seen in [Figure 2-1](#)). Alternatively, the Project Properties window can be opened by clicking on *File > Project Properties*, or by right clicking on the project name in the Projects window and clicking **Properties**.

FIGURE 2-1: PROJECT PROPERTIES BUTTON

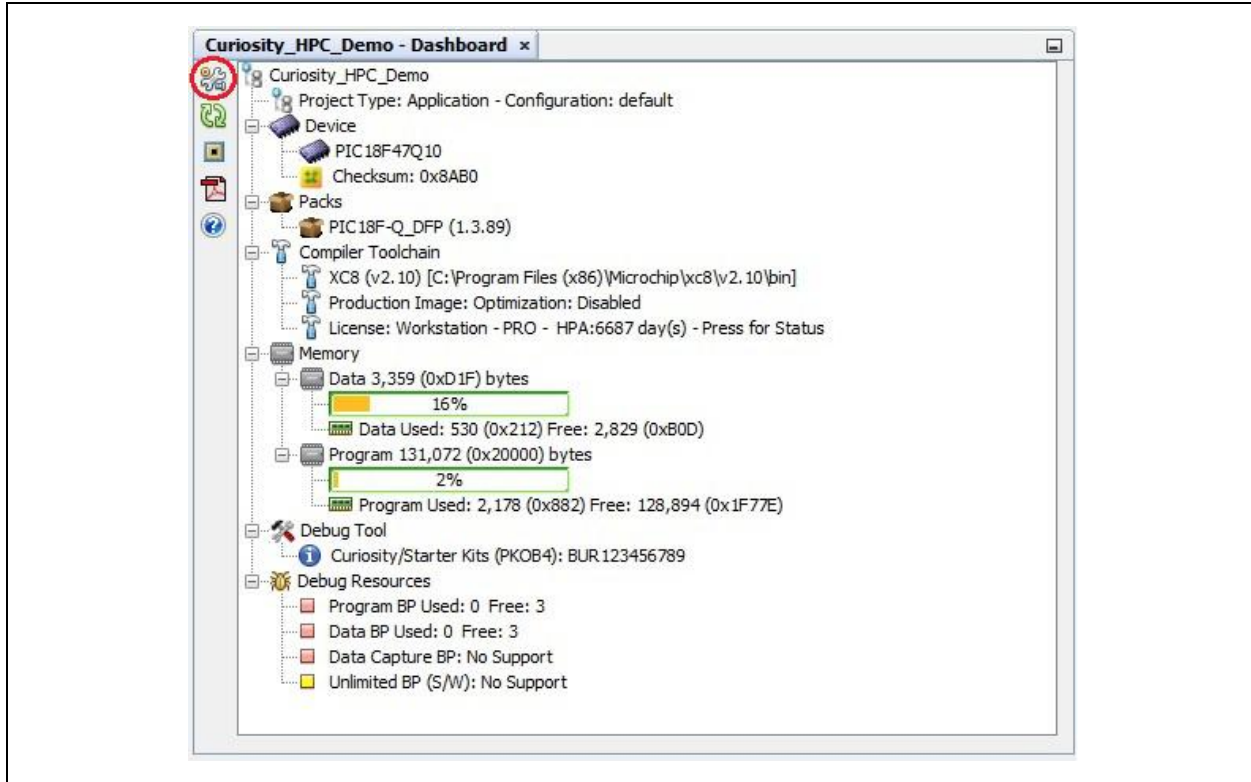

4. The Project Properties window will open. This window allows for the selection of the programming tool, compiler, and PIC MCU. MPLAB X IDE refers to the Curiosity HPC Board as “Starter Kits” in the Hardware Tool selection window as seen in Figure 2-2.

FIGURE 2-2: SELECTING THE CURIOSITY HPC DEVELOPMENT BOARD

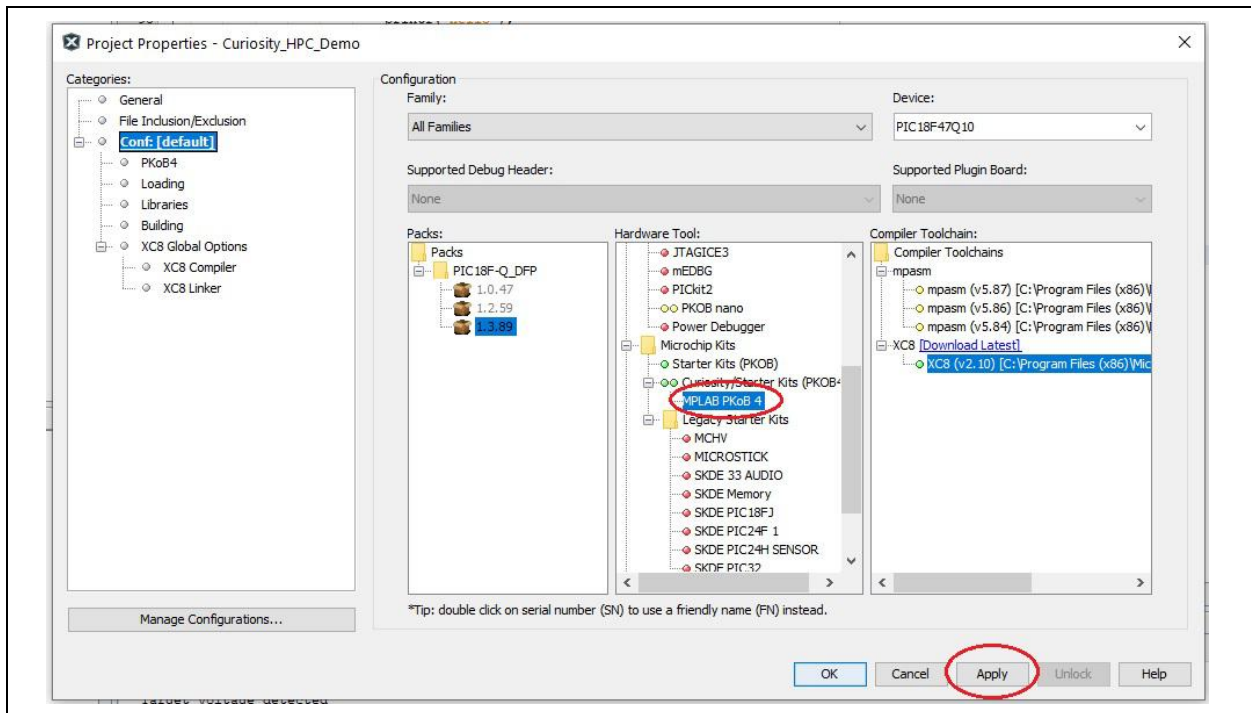

5. In the upper left-hand corner of the Project Properties window, click on **Starter**

Kits (PKOB). The window will now show the configuration options for the PKOB programmer, as shown in [Figure 2-3](#).

FIGURE 2-3: PROGRAM OPTIONS FOR THE PICKit™ ON-BOARD (PKOB)

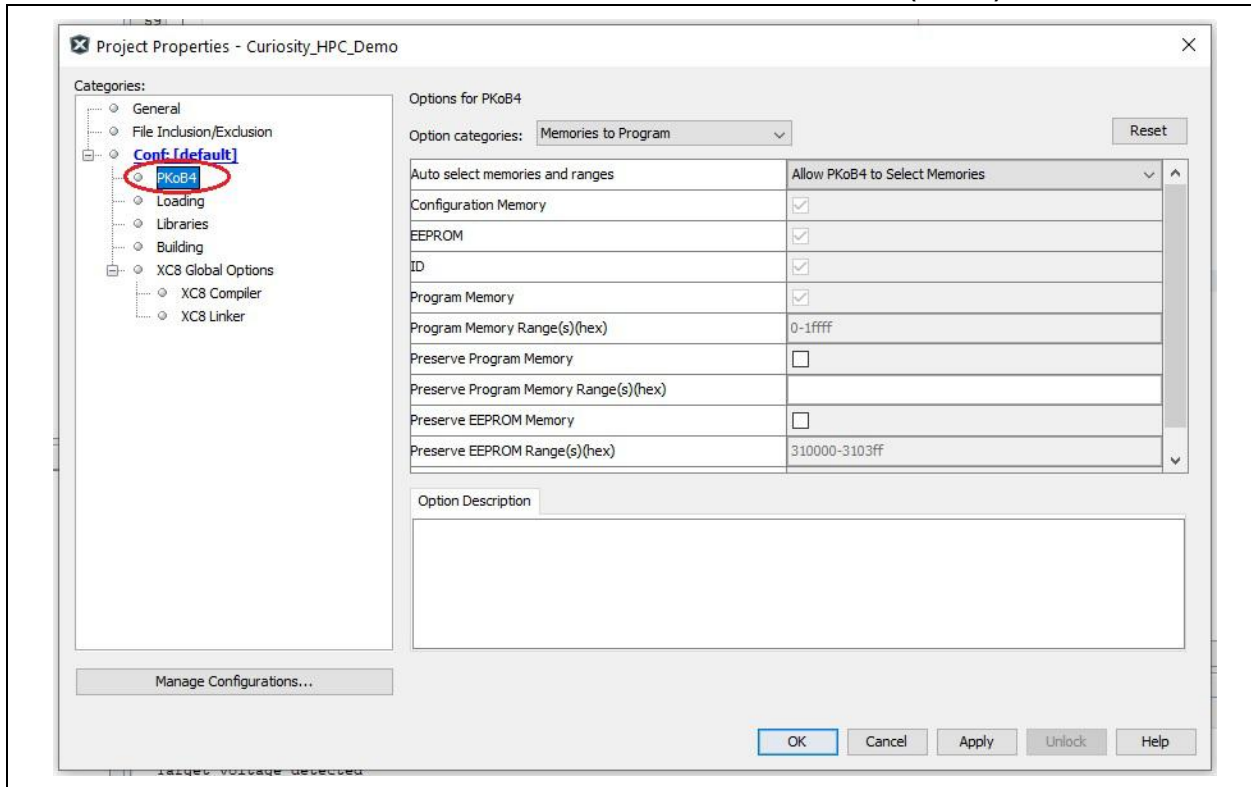

6. In the Option categories drop-down menu, select **Program Options**; ensure that the Low Voltage Programming mode is selected for Programming mode entry (Figure 2-4). The Curiosity HPC Board is now ready to be programmed.

FIGURE 2-4: ENSURE LOW-VOLTAGE PROGRAMMING IS ENABLED

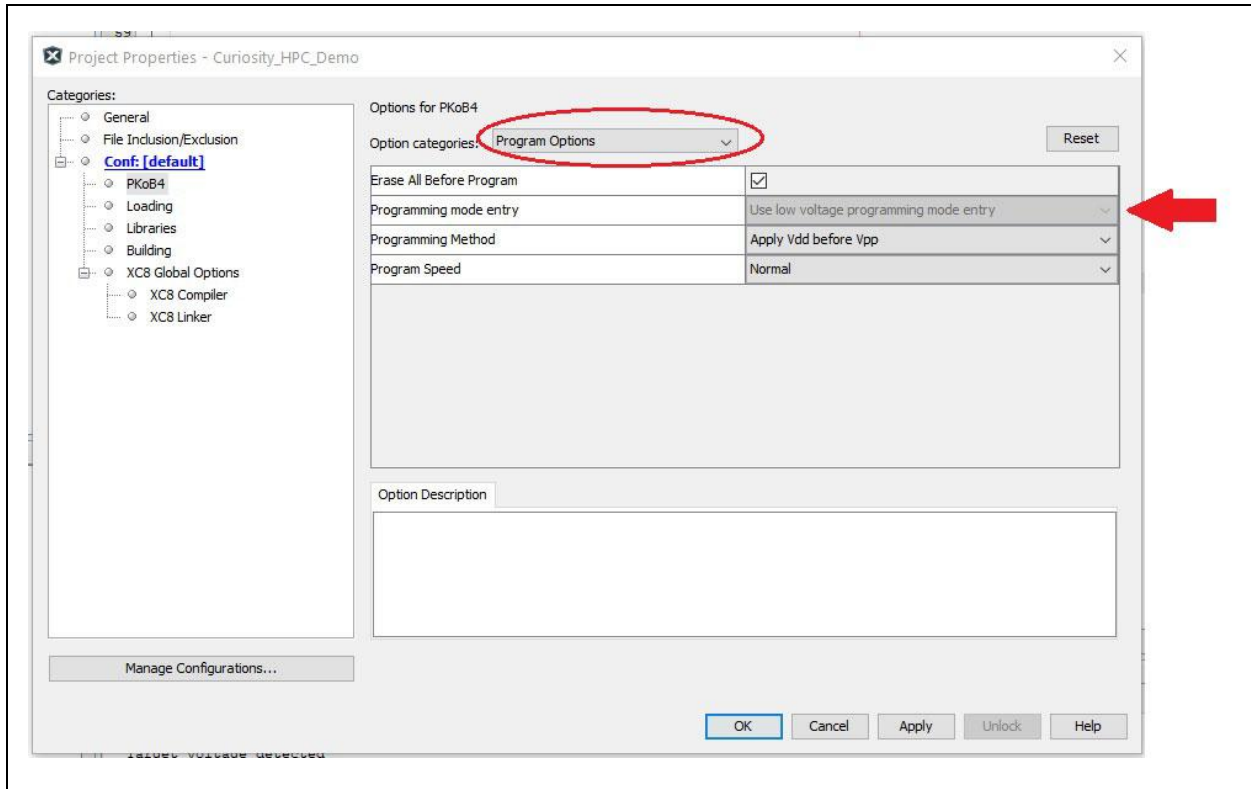

7. Once the project is ready to be programmed, simply click on the **Make and Program Device** button, and MPLAB X IDE will build and compile the code and program the PIC device, as displayed in Figure 2-5.

FIGURE 2-5: DEVICE PROGRAMMING

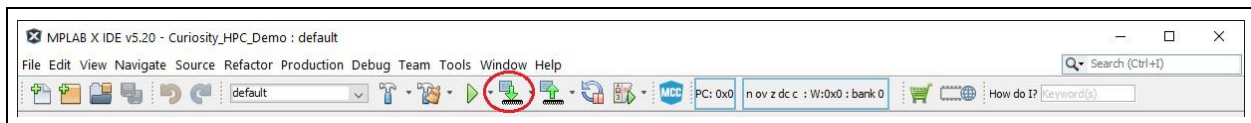

Chapter 3. Troubleshooting

This chapter discusses common operational issues and methods to resolve them.

3.1 THE MCU WILL NOT PROGRAM USING THE PKOB

The Curiosity HPC Development Board's PICKit On-Board (PKOB) uses low-voltage programming. Both MPLAB X IDE and MPLAB Xpress set the Low-Voltage Programming (LVP) bit to a '1', allowing low-voltage programming.

1. When using custom firmware, the LVP bit must be set to '1' in the Configuration Word. MPLAB X IDE will not allow programming using the PKOB unless the bit is properly configured.
2. When using a PIC microcontroller (one not included with the Curiosity Development Board) that has already been programmed using high-voltage programming and the LVP bit is cleared (LVP = OFF or '0'), the device will not be recognized and cannot be programmed using the PKOB. Reprogramming the device can be achieved by one of the following two methods:
 - a) Connect a PICKit™ 3 Programmer to the PIC device dual-row expansion headers, ensuring the appropriate ICSP™, GND, and VDD connections are made. Configure MPLAB X IDE to use the PICKit 3 as the programmer, and ensure the LVP bit is set to '1' in the Configuration Word. Reprogram the device.
 - b) Use an unprogrammed (blank) device and ensure the LVP bit is set to '1' in the Configuration Word.

3.2 THE MPLAB PICKIT™ 4 ON-BOARD (PKOB4) DOES NOT PERFORM

Use the **Hardware Tool Emergency Boot Firmware Recovery Utility** to restore hardware tool boot firmware to its factory state. The recovery utility window can be opened by clicking on *Debug > Hardware Tool Emergency Boot Firmware Recovery Utility* in MPLAB X IDE. The Curiosity HPC Development Board's PICKit On-Board (PKOB) uses low-voltage programming. Both MPLAB X IDE and MPLAB Xpress sets the Low-Voltage Programming (LVP) bit to a '1', allowing low-voltage programming.

Appendix A. Schematic

A.1 CURIOSITY HPC DEVELOPMENT BOARD SCHEMATIC

FIGURE A-1: CURIOSITY HPC DEVELOPMENT BOARD SCHEMATIC REV 1

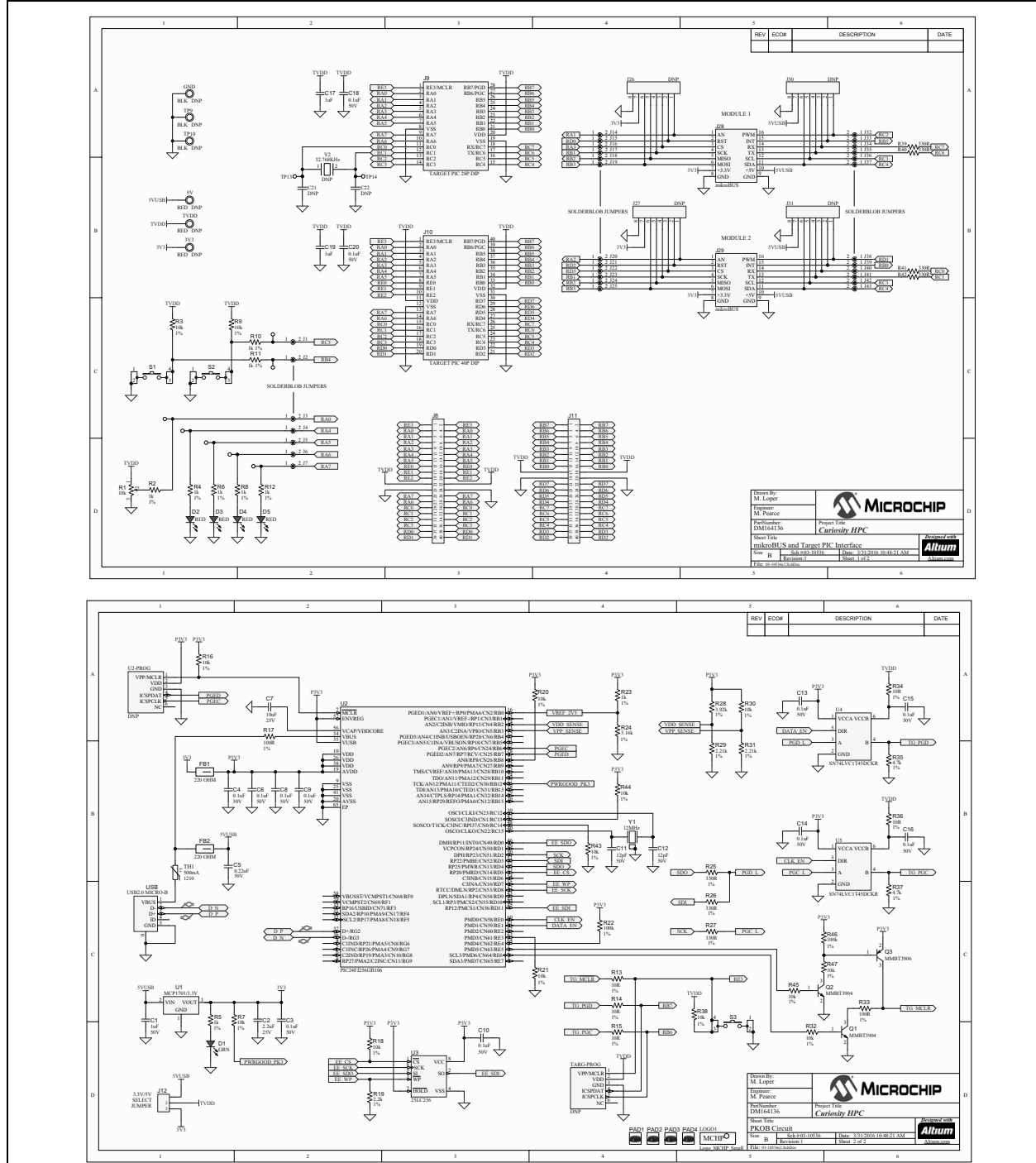

FIGURE A-2: CURIOSITY HPC DEVELOPMENT BOARD SCHEMATIC REV 2 (1 OF 4)

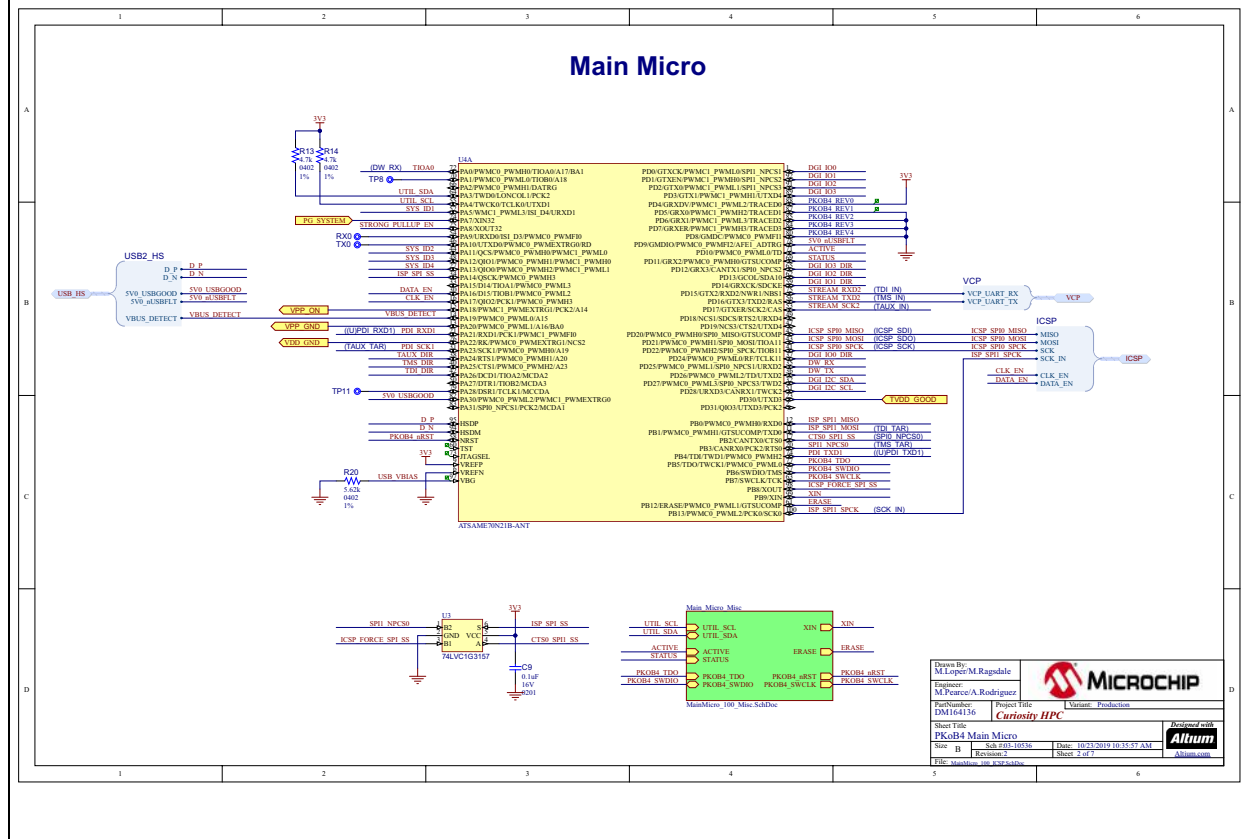
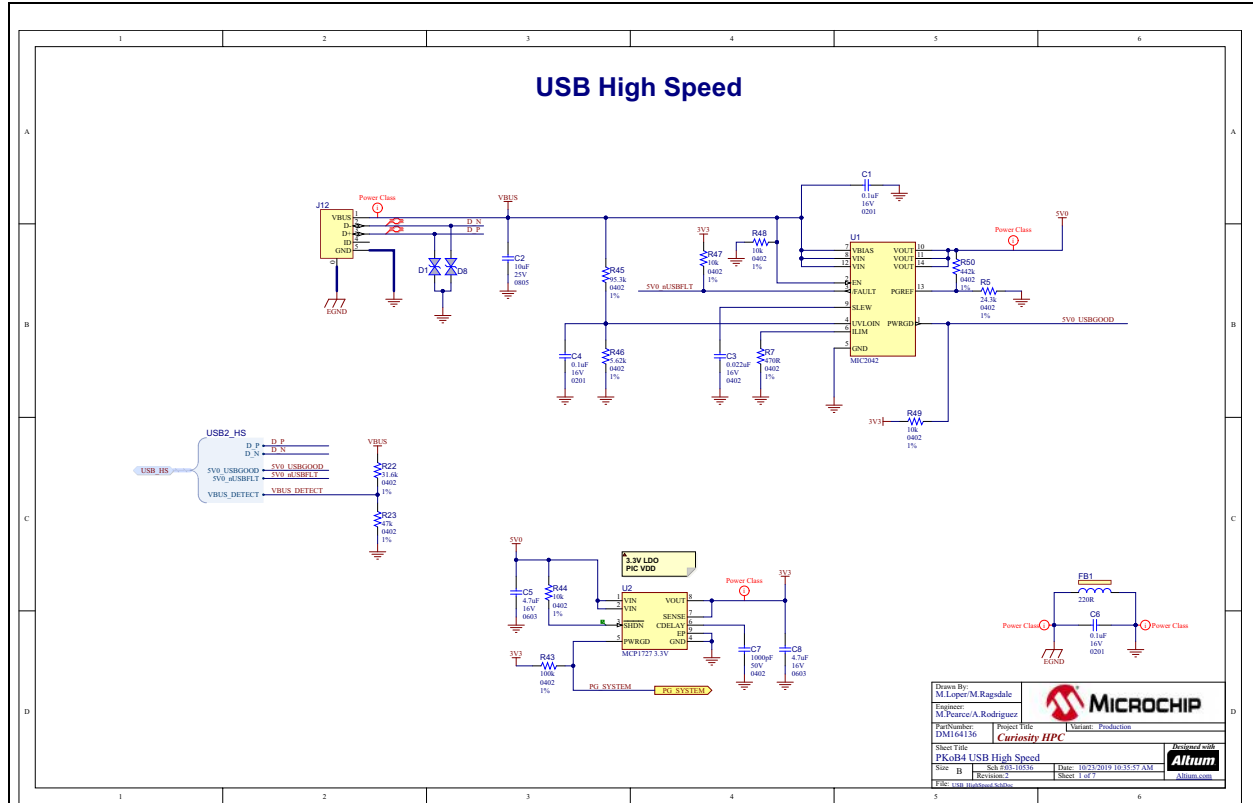

FIGURE A-4: CURIOSITY HPC DEVELOPMENT BOARD SCHEMATIC REV 2 (3 OF 4)

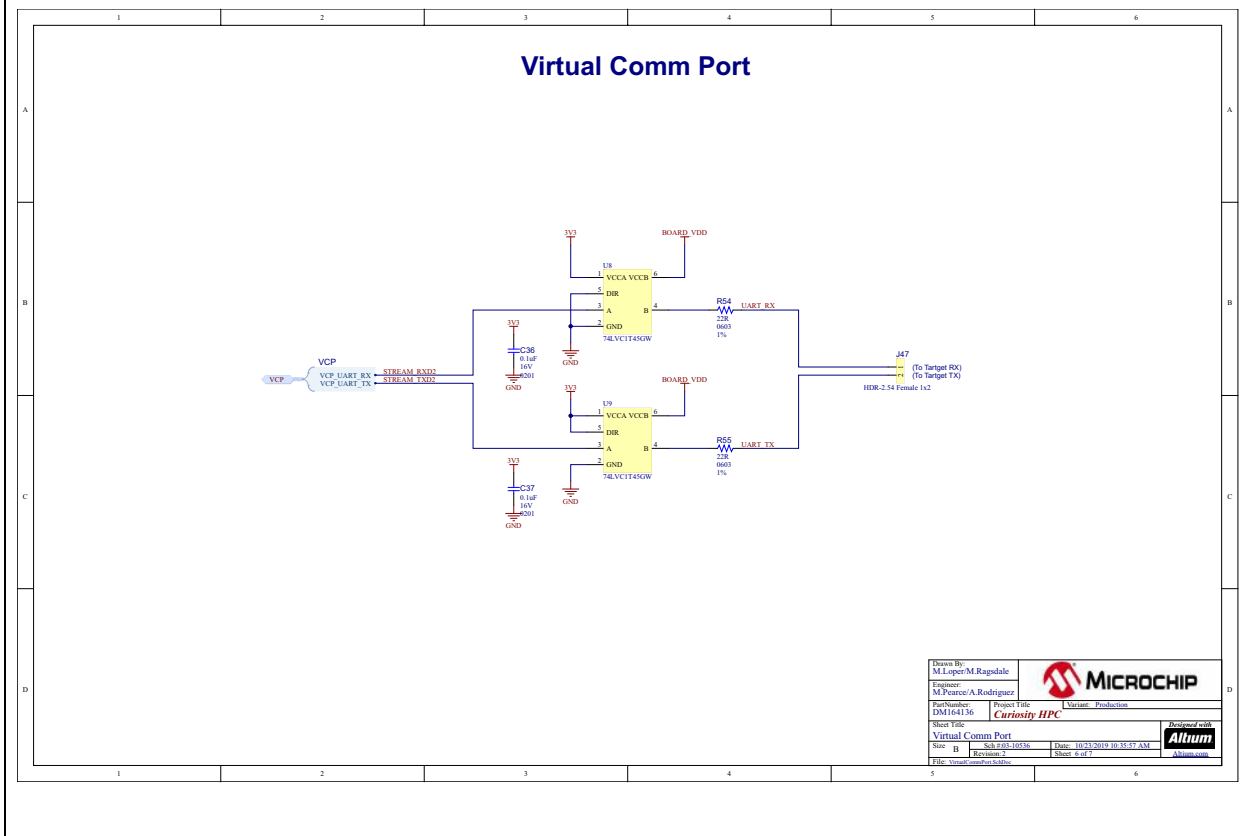
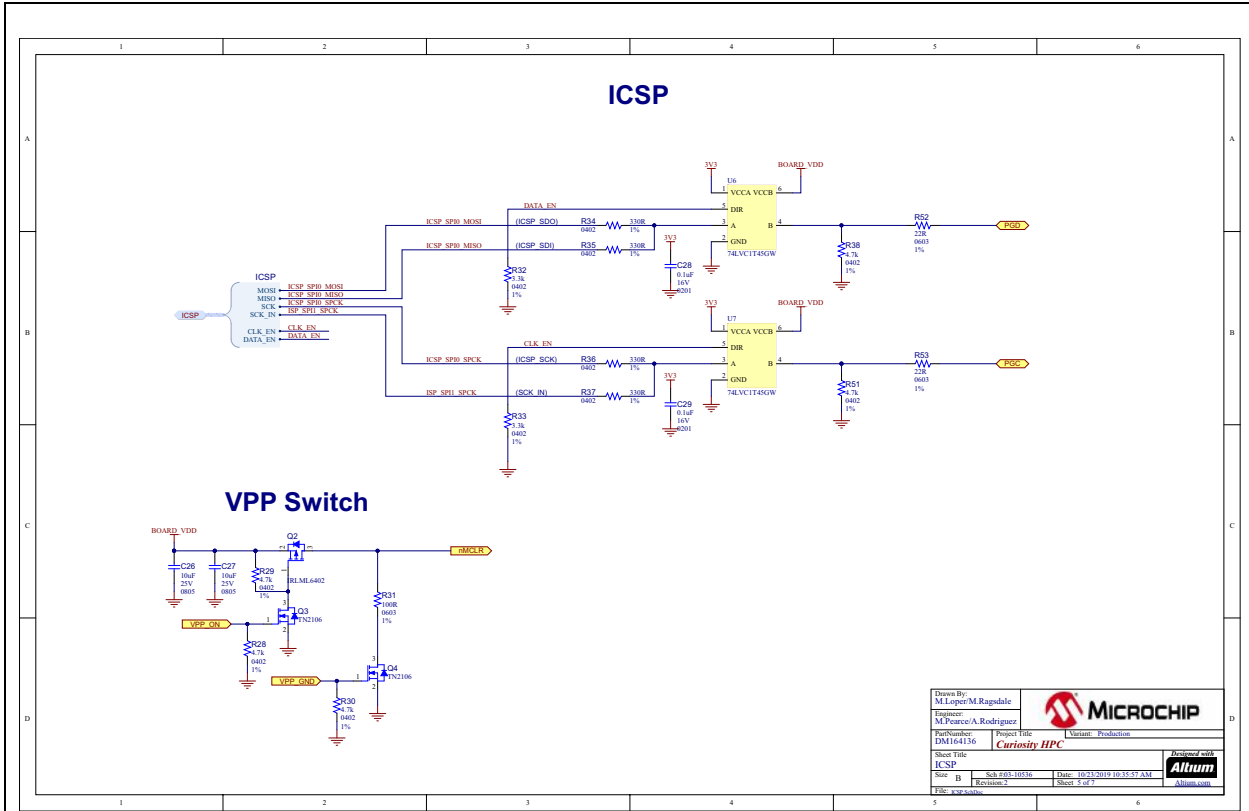
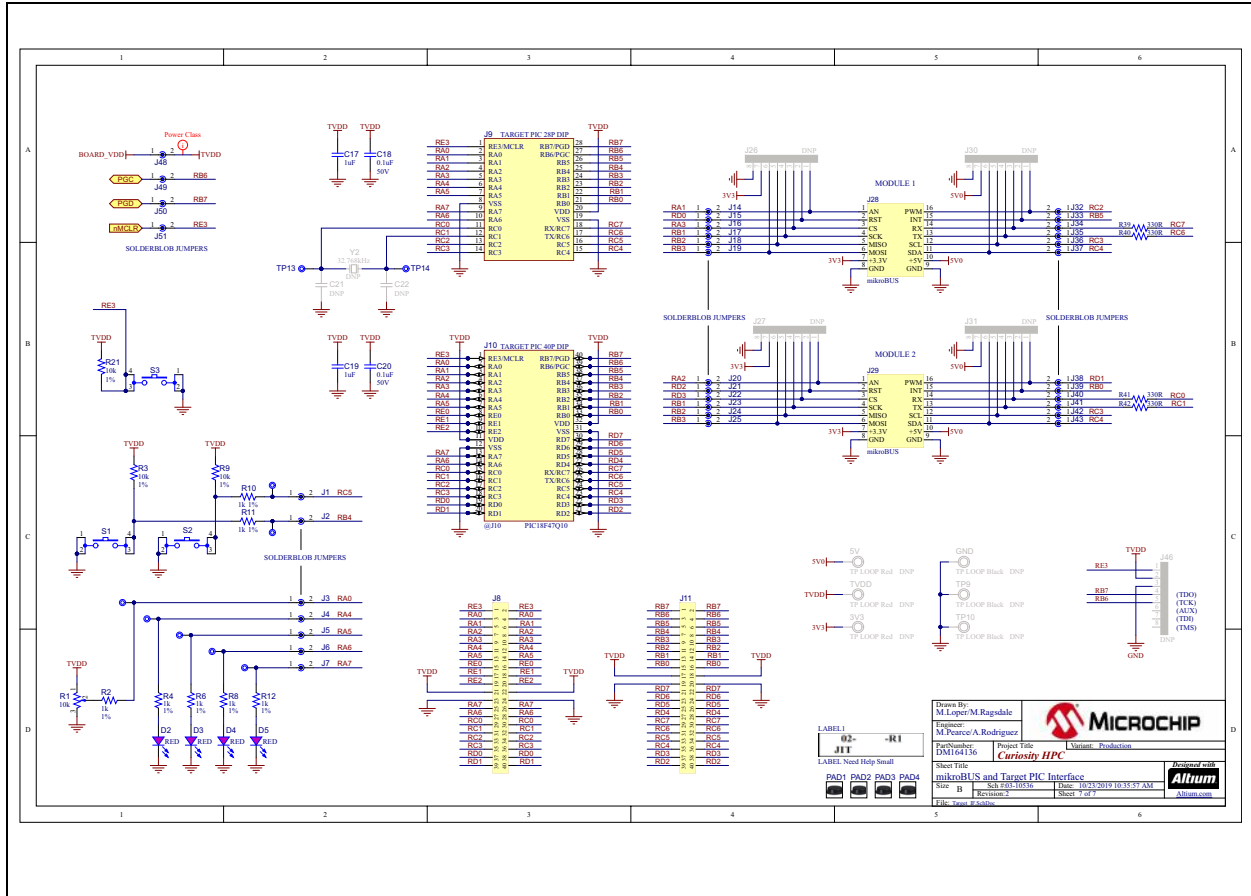

FIGURE A-5: CURIOSITY HPC DEVELOPMENT BOARD SCHEMATIC REV 2 (4 OF 4)



Appendix B. General Notes

B.1 mikroBUS™ CLICKS

Module 1 is the main click socket, and Module 2 is the secondary socket. Both sockets are fully compatible with a 40-pin PIC device; however, when using 28-pin devices, not all pins are available.

All pins in Module 1 are available for use with the exception of the mikroBUS's Reset (RST) signal, which is tied to pin RD0. PORT D is not available on 28-pin devices. If the RST signal is needed, remove the solder blob jumper associated with the mikroBUS RST connection, and place a jumper wire between the via next to the solder blob jumper and the desired pin connection found in the J8 or J11 dual-row expansion headers (see [Figure 1-2](#)).

All pins in Module 2 are available for use with the exception of the mikroBUS's Reset (RST) signal (RD2), SPI Chip Select (\overline{CS}) signal (RD3), and the PWM (RD1) signal. These signals are routed to the PORT D pins, which are not available on 28-pin PIC devices. If these signals are needed, remove the solder blob jumpers associated with the mikroBUS connection pins, and place jumper wires from the vias located next to the associated solder blob jumpers to the desired pin connections found in the J8 or J11 dual-row expansion headers (see [Figure 1-2](#)).

B.2 SOLDER BLOB JUMPER

Solder blob jumpers can be found on each Click module, push-button switch, LED, or potentiometer connection. This allows the user to utilize those pin connections for other applications.



MICROCHIP

Worldwide Sales and Service

AMERICAS

Corporate Office
2355 West Chandler Blvd.
Chandler, AZ 85224-6199
Tel: 480-792-7200
Fax: 480-792-7277
Technical Support:
<http://www.microchip.com/support>
Web Address:
www.microchip.com

Atlanta

Duluth, GA
Tel: 678-957-9614
Fax: 678-957-1455

Austin, TX

Tel: 512-257-3370

Boston

Westborough, MA
Tel: 774-760-0087
Fax: 774-760-0088

Chicago

Itasca, IL
Tel: 630-285-0071
Fax: 630-285-0075

Dallas

Addison, TX
Tel: 972-818-7423
Fax: 972-818-2924

Detroit

Novi, MI
Tel: 248-848-4000

Houston, TX

Tel: 281-894-5983

Indianapolis

Noblesville, IN
Tel: 317-773-8323
Fax: 317-773-5453
Tel: 317-536-2380

Los Angeles

Mission Viejo, CA
Tel: 949-462-9523
Fax: 949-462-9608
Tel: 951-273-7800

Raleigh, NC

Tel: 919-844-7510

New York, NY

Tel: 631-435-6000

San Jose, CA

Tel: 408-735-9110
Tel: 408-436-4270

Canada - Toronto

Tel: 905-695-1980
Fax: 905-695-2078

ASIA/PACIFIC

Australia - Sydney
Tel: 61-2-9868-6733

China - Beijing
Tel: 86-10-8569-7000

China - Chengdu
Tel: 86-28-8665-5511

China - Chongqing
Tel: 86-23-8980-9588

China - Dongguan
Tel: 86-769-8702-9880

China - Guangzhou
Tel: 86-20-8755-8029

China - Hangzhou
Tel: 86-571-8792-8115

China - Hong Kong SAR
Tel: 852-2943-5100

China - Nanjing
Tel: 86-25-8473-2460

China - Qingdao
Tel: 86-532-8502-7355

China - Shanghai
Tel: 86-21-3326-8000

China - Shenyang
Tel: 86-24-2334-2829

China - Shenzhen
Tel: 86-755-8864-2200

China - Suzhou
Tel: 86-186-6233-1526

China - Wuhan
Tel: 86-27-5980-5300

China - Xian
Tel: 86-29-8833-7252

China - Xiamen
Tel: 86-592-2388138

China - Zhuhai
Tel: 86-756-3210040

ASIA/PACIFIC

India - Bangalore
Tel: 91-80-3090-4444

India - New Delhi
Tel: 91-11-4160-8631

India - Pune
Tel: 91-20-4121-0141

Japan - Osaka
Tel: 81-6-6152-7160

Japan - Tokyo
Tel: 81-3-6880-3770

Korea - Daegu
Tel: 82-53-744-4301

Korea - Seoul
Tel: 82-2-554-7200

Malaysia - Kuala Lumpur
Tel: 60-3-7651-7906

Malaysia - Penang
Tel: 60-4-227-8870

Philippines - Manila
Tel: 63-2-634-9065

Singapore
Tel: 65-6334-8870

Taiwan - Hsin Chu
Tel: 886-3-577-8366

Taiwan - Kaohsiung
Tel: 886-7-213-7830

Taiwan - Taipei
Tel: 886-2-2508-8600

Thailand - Bangkok
Tel: 66-2-694-1351

Vietnam - Ho Chi Minh
Tel: 84-28-5448-2100

EUROPE

Austria - Wels
Tel: 43-7242-2244-39
Fax: 43-7242-2244-393

Denmark - Copenhagen
Tel: 45-4450-2828
Fax: 45-4485-2829

Finland - Espoo
Tel: 358-9-4520-820

France - Paris
Tel: 33-1-69-53-63-20
Fax: 33-1-69-30-90-79

Germany - Garching
Tel: 49-8931-9700

Germany - Haan
Tel: 49-2129-3766400

Germany - Heilbronn
Tel: 49-7131-72400

Germany - Karlsruhe
Tel: 49-721-625370

Germany - Munich
Tel: 49-89-627-144-0
Fax: 49-89-627-144-44

Germany - Rosenheim
Tel: 49-8031-354-560

Israel - Ra'anana
Tel: 972-9-744-7705

Italy - Milan
Tel: 39-0331-742611
Fax: 39-0331-466781

Italy - Padova
Tel: 39-049-7625286

Netherlands - Drunen
Tel: 31-416-690399
Fax: 31-416-690340

Norway - Trondheim
Tel: 47-7288-4388

Poland - Warsaw
Tel: 48-22-3325737

Romania - Bucharest
Tel: 40-21-407-87-50

Spain - Madrid
Tel: 34-91-708-08-90
Fax: 34-91-708-08-91

Sweden - Gothenberg
Tel: 46-31-704-60-40

Sweden - Stockholm
Tel: 46-8-5090-4654

UK - Wokingham
Tel: 44-118-921-5800
Fax: 44-118-921-5820