

Introduction

The WBZ351 Curiosity Board is a development platform that supports rapid prototyping and demonstrates the features, capabilities and interfaces of Microchip's Bluetooth® Low Energy and Zigbee® RF Module (WBZ351PE).

The WBZ351 Curiosity Board:

- Offers integrated programming/debugging features using the PICkit™ On-board 4 (PKOB4) debugger interface
- Requires only a Micro-B USB cable to power up and program the WBZ351PE Module
- Includes a mikroBUS™ Click™ header, which helps the users to expand the functionalities by connecting to various MikroElektronika mikroBUS Click adapter boards
- Includes an Xplained Pro (XPRO) header to interface with the QT7/T9 XPRO kit to integrate touch button support and demonstrate the touch feature
- Enables rapid prototyping utilizing the WBZ351PE Module

The WBZ351 Curiosity Board supports a wide range of applications. The following are a few of them:

- Wireless lighting (Zigbee or Bluetooth low energy)
- Home automation (Door locks and alarm sensors)
- Internet of Things (IoT) (Wall switches and thermostats)
- Industrial automation

Features

- On-Board WBZ351PE, a Fully RF Certified Wireless Module and Qualified for Bluetooth Low Energy 5.2 Specifications
- USB or Li-Po Battery Powered
- On-Board Programmer/Debug Circuit Using PKOB4 Based on Microchip SAME70 MCU
- Microchip MCP73871 Li-Ion/LiPo Battery Charger with Power Path Management
- On-Board USB-to-UART Serial Converter with Hardware Flow Control Based on Microchip MCP2200
- mikroBUS Socket to Expand Functionality Using MikroElektronika Click Adapter Boards
- XPRO Header to Interface with QT7/T9 XPRO Kits to Evaluate and Demonstrate the WBZ351PE Module's Touch Capabilities
- RGB LED Connected to Pulse Width Modulation (PWM)
- One Reset Switch
- Two User Configurable Buttons
- One User LED
- 32.768 kHz SOSC Crystal for the WBZ351PE Module
- Microchip SST26VF064B-104I/MF, 64-Mbit External QSPI Flash Memory
- Microchip MCP9700A, Low Power Analog Voltage Temperature Sensor

- 10-Pin ARM® Serial Wire Debug (SWD) Header for External Programmer/Debugger
- For more details, refer to [3. Hardware](#).

Table of Contents

Introduction.....	1
Features.....	1
1. Quick References.....	5
1.1. Reference Documentation.....	5
1.2. Hardware Prerequisites.....	5
1.3. Software Prerequisites.....	5
1.4. Acronyms and Abbreviations.....	5
2. Kit Overview.....	7
2.1. Kit Contents.....	8
3. Hardware.....	9
3.1. Power Supply.....	10
3.2. Lithium Battery Charger (U12).....	11
3.3. External Power Supply Header (J5).....	12
3.4. USB Connectivity using Microchip USB 2.0 Hub Controller.....	12
3.5. PICkit On-Board 4 (PKoB4) and Debugger/Programmer Selection (U20).....	13
3.6. USB-to-UART Serial Converter (U18).....	14
3.7. mikroBUS Socket (J4).....	15
3.8. XPRO Header (J20).....	16
3.9. Switches.....	17
3.10. LEDs.....	17
3.11. Temperature Sensor (U3).....	18
3.12. QSPI Serial Flash (U7).....	18
3.13. 32.768 kHz Secondary Oscillator.....	18
3.14. WBZ351PE Module.....	19
3.15. Limitations of Using Battery and External Power Supply	19
4. WBZ351 Curiosity Board Out of Box Demo.....	20
5. Appendix A: Reference Circuit.....	21
5.1. WBZ351 Curiosity Board Reference Schematics.....	21
5.2. WBZ351 Curiosity Board Bill of Materials.....	36
6. Appendix B: PKOB4 Recovery Method	37
7. Appendix: B Regulatory Approval.....	39
7.1. United States.....	39
7.2. Canada.....	40
7.3. Europe.....	40
8. Document Revision History.....	41
Microchip Information.....	42
The Microchip Website.....	42
Product Change Notification Service.....	42
Customer Support.....	42

Microchip Devices Code Protection Feature..... 42
Legal Notice..... 42
Trademarks..... 43
Quality Management System..... 44
Worldwide Sales and Service..... 45

1. Quick References

1.1 Reference Documentation

For further details, refer to the following:

- *PIC32CX-BZ3 and WBZ35x Family Data Sheet* (DS70005541)
- *MPLAB® XC32 C/C++ Compiler User's Guide* (DS50001686)
- *MPLAB® X IDE User's Guide* (DS50002027)
- *MPLAB® Snap In-Circuit Debugger Information Sheet* (DS50002787)
- *MCP1727 1.5A, Low Voltage, Low Quiescent Current LDO Regulator Data Sheet* (DS21999)
- *SST26VF064B/SST26VF064BA 2.5V/3.0V 64-Mbit Serial Quad I/O™ (SQI™) Flash Memory Data Sheet* (DS20005119)
- *Stand-Alone System Load Sharing and Li-Ion/Li-Polymer Battery Charge Management Controller Data Sheet* (DS20002090)
- *MCP9700A, Low-Power Linear Active Thermistor IC Data Sheet* (DS20001942)
- [PIC32CXBZ3/WBZ35 Application Developer's Guide](#)
- *Universal Serial Bus Specification and Associated Documents* (www.usb.org)
- *mikroBUS™ Specification* (www.mikroe.com/mikrobus)

1.2 Hardware Prerequisites

- WBZ351 Curiosity Board
- Type-A male to Micro-B USB cable
- Li-ion Polymer Battery – 4.2V for battery powered application
- Bluetooth enabled Smartphone:
 - Android™ device
 - iOS – iPhone®
- QT7 Xplained Pro Extension Kit ([ATQT7-XPRO](#))

1.3 Software Prerequisites

- MPLAB® Integrated Development Environment ([MPLAB® X IDE](#)) tool (version 5.50 or later)
- [MPLAB® XC32 Compiler](#) (version 2.40 or later)
- [Out of Box \(OOB\) demo](#)

1.4 Acronyms and Abbreviations

Table 1-1. Acronyms/Abbreviations

Acronyms/Abbreviations	Description
ADC	Analog-to-Digital Converter
BOM	Bill of Material
GPIO	General Purpose Input Output
I ² C	Inter-Integrated Circuit
ICD	In-Circuit Debugger
IoT	Internet of Things
LDO	Low-Dropout (Regulator)
LED	Light Emitting Diode
MCU	Microcontroller

.....continued

Acronyms/Abbreviations	Description
NC	Not Connected
OOB	Out of Box
PCB	Printed Circuit Board
PKOB	PICKit On-Board
PPS	Peripheral Pin Select
PTC	Peripheral Touch Controller
PWM	Pulse Width Modulation
RTCC	Real Time Clock and Calendar
RX	Receiver
SCL	Serial Clock
SDA	Serial Data
SMD	Surface Mount Device
SoC	System-on-Chip
SPI	Serial Peripheral Interface
SWD	Serial Wire Debug
TX	Transmitter
UART	Universal Asynchronous Receiver-Transmitter
USB	Universal Serial Bus
UVLO	Undervoltage Lockout

2. Kit Overview

The WBZ351 Curiosity Board contains a WBZ351PE Module. All the signals from the WBZ351PE Module are connected to on-board features of the Curiosity Board for flexibility and rapid prototyping.

Figure 2-1. WBZ351 Curiosity Board (EV19J06A) – Top View

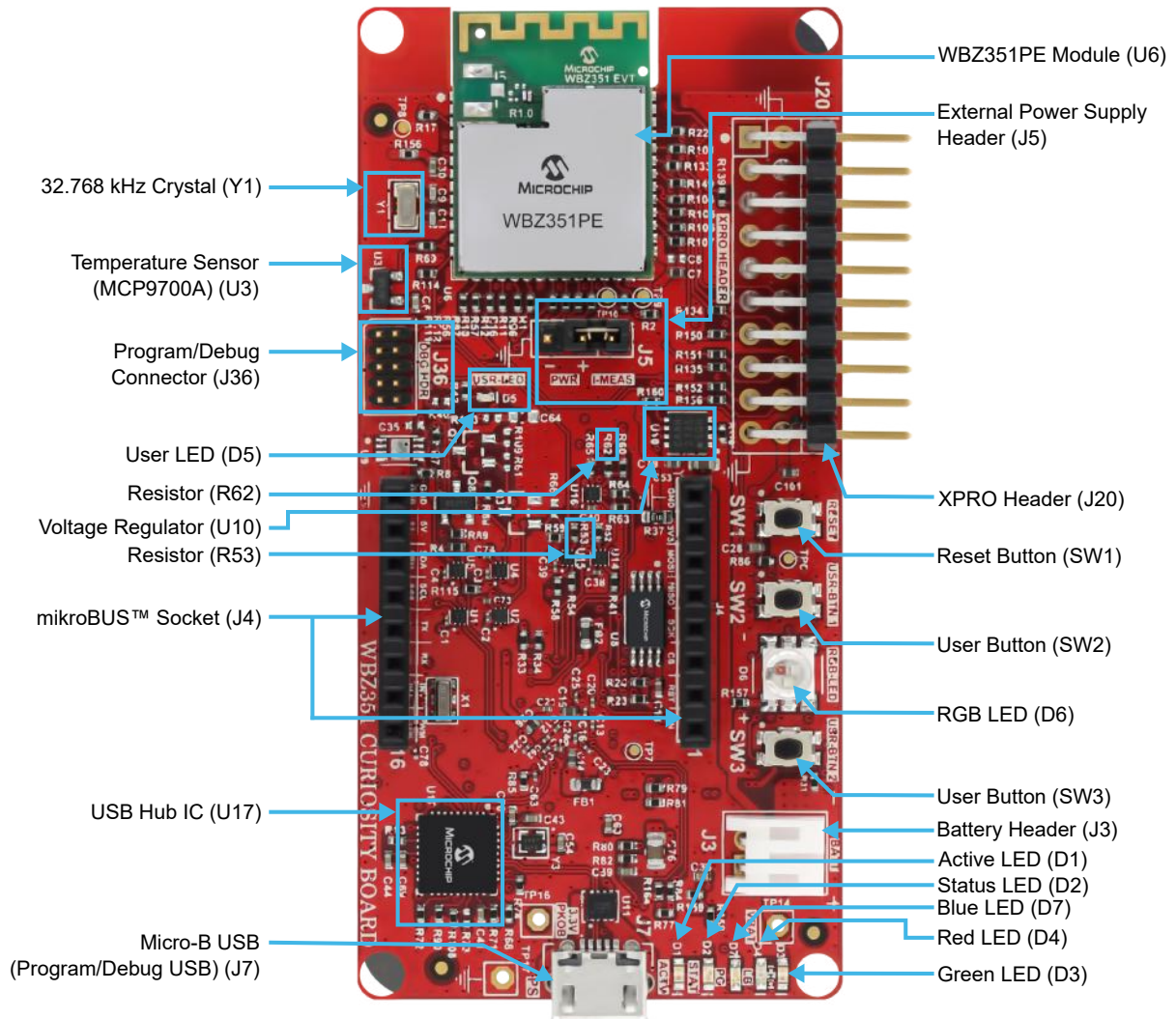
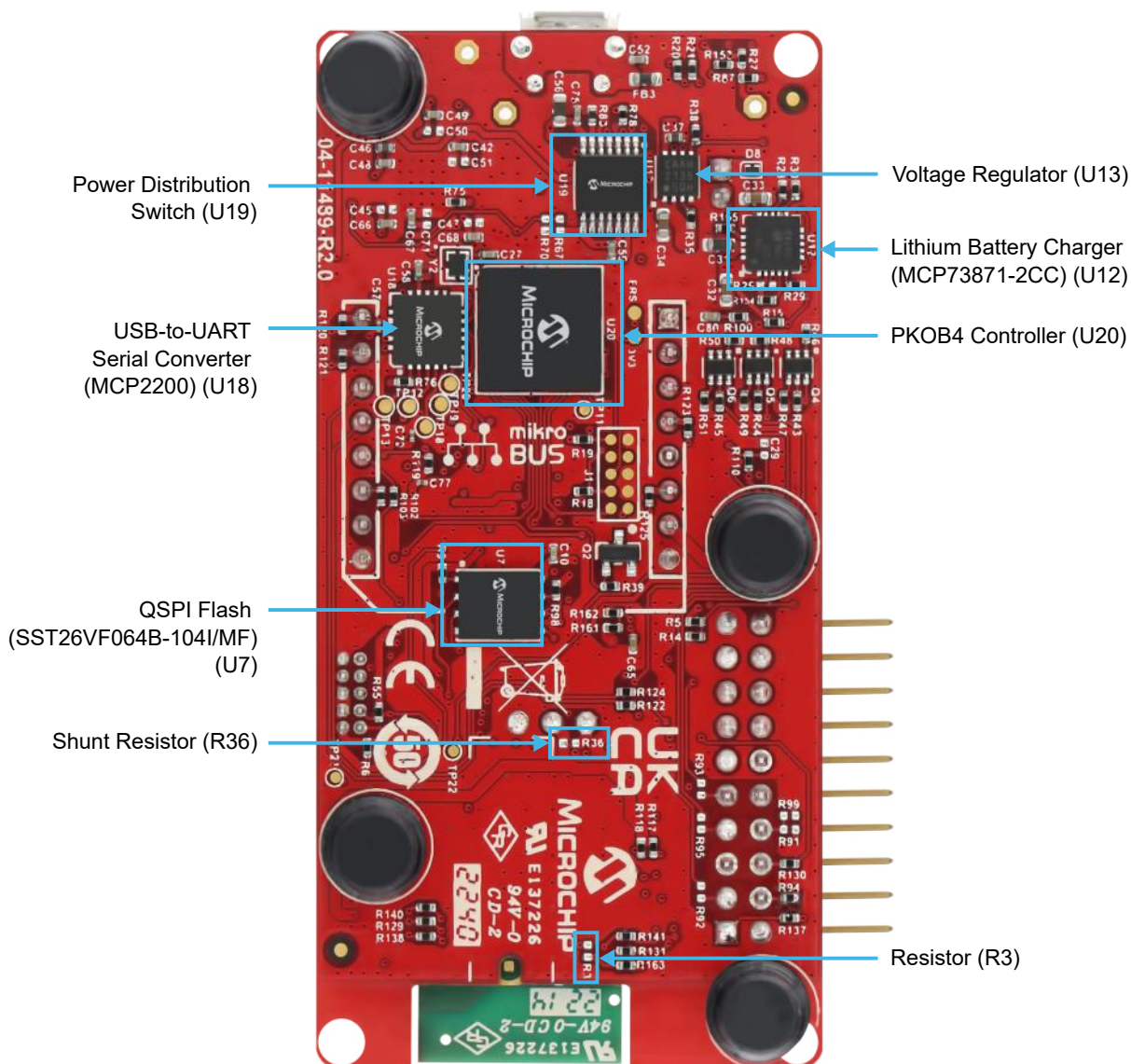

Figure 2-2. WBZ351 Curiosity Board (EV19J06A) – Bottom View



2.1 Kit Contents

The EV19J06A (WBZ351 Curiosity Board) kit contains the following:

- A WBZ351PE Module mounted on the WBZ351 Curiosity Board
- A Type-A male to Micro-B USB cable

Note: If any of the above items are missing in the kit, go to support.microchip.com or contact your local Microchip Sales office. In this user guide, there is a list of Microchip offices for sales and services provided on the last page.

3. Hardware

This chapter describes the hardware features of the WBZ351 Curiosity Board.

Figure 3-1. WBZ351 Curiosity Board Block Diagram

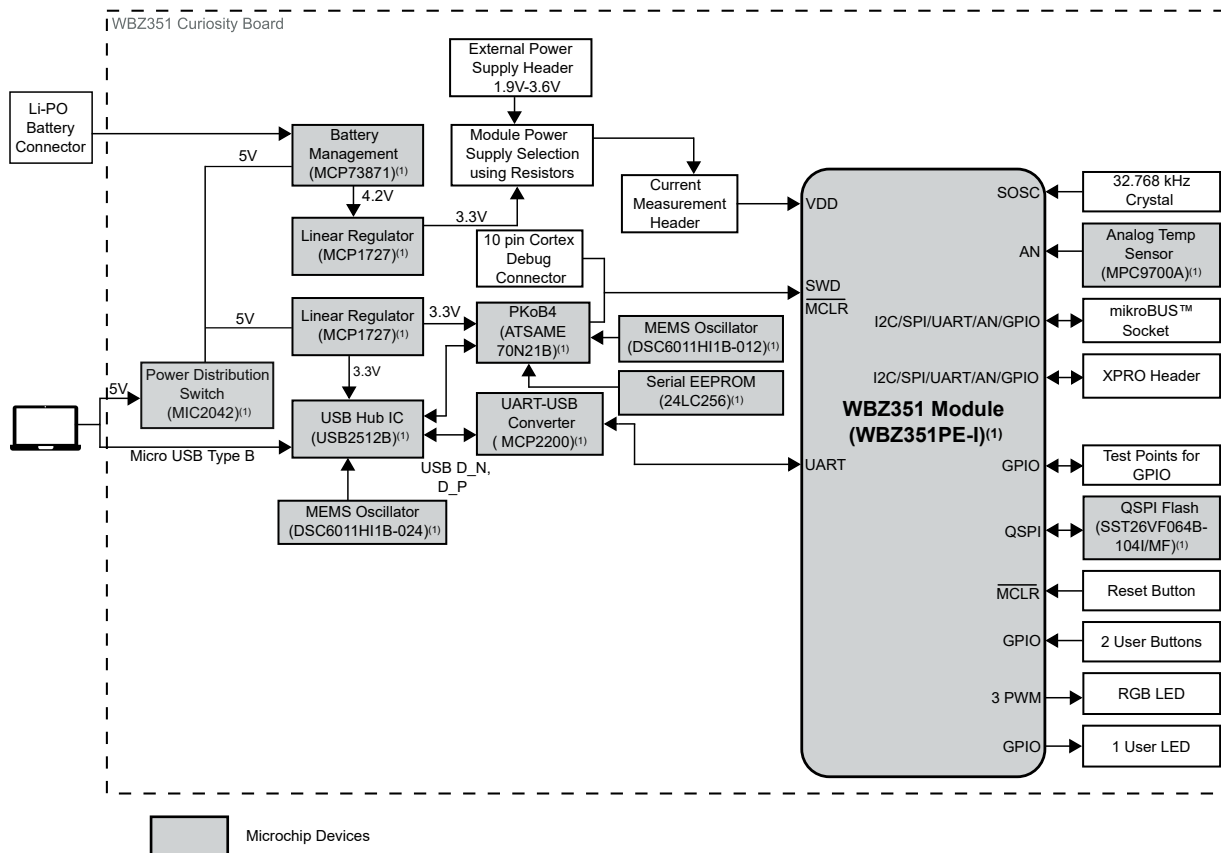

Note:

- Using Microchip’s total system solution, which includes complementary devices, software drivers and reference designs, is highly recommended to ensure the proven performance of the WBZ351 Curiosity Boards. For more details, go to support.microchip.com or contact your local Microchip Sales office.

Table 3-1. Microchip Components used in WBZ351 Curiosity Board

S.No.	Designator	Manufacturer Part Number	Description
1	Q2, Q8	TN2106K1-G	MCHP Analog MOSFET N-CH TN2106 60V 280 mA 360 mW 2.5R SOT23-3
2	U3	MCP9700AT-E/TT	MCHP Analog Temperature Sensor -40°C to +150°C MCP9700AT-E/TT SOT-23-3
3	U6	WBZ351PE-I	Wireless Module Bluetooth® Low Energy/Zigbee WBZ351PEI, with PCB Antenna, 39-LGA, 15.5x20.7 mm
4	U7	SST26VF064B-104I/MF	MCHP Serial Flash SST26VF064B-104I/MF WDFN-8
5	U8	24LC256T-E/ST	MCHP Memory Serial EEPROM 256k I2C 24LC256T-E/ST TSSOP-8
6	U10, U13	MCP1727T-ADJE/MF	MCHP Analog LDO 0.8-5V MCP1727ADJE/MF DFN-8
7	U12	MCP73871-2CCI/ML	MCHP Analog Battery Charger MCP73871-2CCI/ML QFN-20

.....continued

S.No.	Designator	Manufacturer Part Number	Description
8	U17	USB2512B-I/M2	MCHP Interface USB 2.0 Hub Controller USB2512B-I/M2 SQFN-36
9	U18	MCP2200-I/MQ	MCHP Interface USB UART MCP2200- I/MQ QFN-20
10	U19	MIC2042-1YTS	MCHP Analog Power Switch 5.5V 3A MIC2042-1YTS TSSOP-14
11	U20	ATSAME70N21B-CNT	MCHP MCU 32-BIT 300 MHz 2 MB 384K x 8 ATSAME70N21B-CNT TFBGA-100
12	Y2	DSC6011HI1B-012.0000	MCHP CMOS Oscillator 12 MHz DSC6011HI1B-012.0000 SMD VFLGA-4
13	Y3	DSC6011HI1B-024.0000	MCHP CMOS Oscillator 24 MHz DSC6011HI1B-024.0000 SMD VFLGA-4

3.1 Power Supply

The following are the list of sources to power the WBZ351 Curiosity Board:

1. A host PC can power the WBZ351 Curiosity Board over USB using a Type-A-to-Micro-B USB cable connected to a Micro-B USB connector (J7).
2. 4.2V Lithium battery (Li-ion/Li-Po) battery kit as follows:
 - Connected to battery header (J3), JST PH, 2-pin, 2 mm pitch and right-angle male battery header
 - Crimp style connector, battery polarity according to +/- marking on the board
 - Battery is not part of the kit
 - Minimum recommended battery capacity is 400 mAh with a battery charge voltage of 4.2V

Battery management circuit automatically handles selection between the USB power supply and battery supply.

The following are the two on-board MCP1727 voltage regulators on the WBZ351 Curiosity Board that power the circuitry on-board.

- Voltage regulator (U10) – Generates 3.3V that powers the WBZ351PE Module along with the associated circuits
- Voltage regulator (U13) – Generates 3.3V that powers the USB hub IC (U201), PKOB4 main controller (U300), along with the associated circuits that connect the PKOB4 debugger to a host PC and MCP2200 USB to UART converter

For more details on the U10 and U13 voltage regulators, refer to the *MCP1727 1.5A, Low Voltage, Low Quiescent Current LDO Regulator Data Sheet* (DS21999).

Figure 3-2. WBZ351 Curiosity Board Power Supply Block Diagram

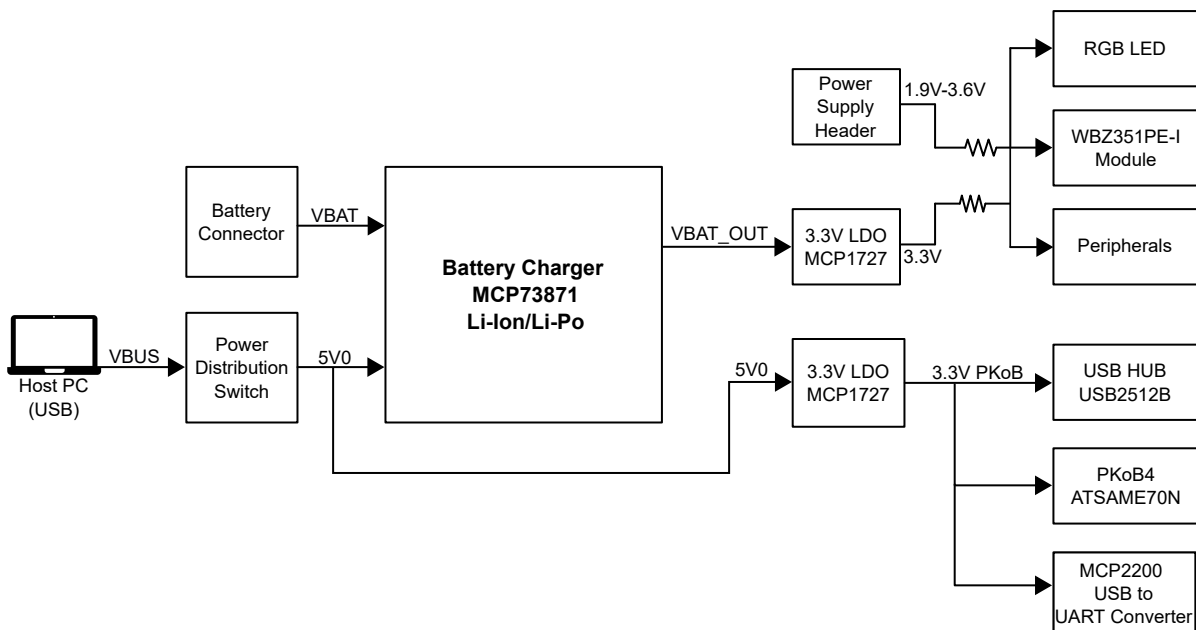

The WBZ351PE Module and associated peripherals can also be powered from:

- External power supply header (J5) using an external power supply (1.9-3.6V) for testing at different voltage levels apart from the default supply of 3.3V from the on-board regulator. To use the external power supply header, disconnect the on-board 3.3V supply according to the following table:

Table 3-2. Jumper Option (J5) to Select the WBZ351PE Module Power Supply

On-board 3.3V Regulator	External Power Supply
Short J5 pin 1 and pin 2, with shunt resistor (R36) mounted (default configuration)	Use J5 pin 2 for external power and J5 pin 3 for GND connection. Do not mount R36.

Note: The maximum available current from the PC host USB is limited to 500 mA. The current is shared between charging the external battery (if connected) and the target application section.

3.2 Lithium Battery Charger (U12)

A 4.2V lithium battery connected to the 2-pin, 2 mm pitch right-angle male battery header can be charged using lithium battery charger (MCP73871-2CC) (U12) from the USB power supply at 100 mA fast charge current.

Battery management circuit automatically handles selection between USB power supply and battery supply. The current is shared between charging the battery (if connected) and the target application section. For more details on the MCP73871 Lithium battery charger, refer to the *Stand-Alone System Load Sharing and Li-Ion/Li-Polymer Battery Charge Management Controller Data Sheet* (DS20002090).

Table 3-3. Battery Charger Status LED

LED Color	Function
Red (D4)	<ul style="list-style-type: none"> Connected to pin 8 (STAT1)/(LBO bar) (active low signal) of MCP73871 STAT1 – Charge status indication. The LBO feature indicates when the battery is running low while operating with battery only. Triggered, if the voltage is <3.1V. The STA1/LBO is also connected to WBZ351PE (PA3) to signal the battery charge status to the WBZ351PE Module.
Blue (D7)	<ul style="list-style-type: none"> Connected to pin 6 Power Good (PG bar (active low signal)) of MCP73871 The PG output is low whenever the input to the MCP73871 is above the Undervoltage Lockout (UVLO) threshold and greater than the battery voltage.
Green (D3)	<ul style="list-style-type: none"> Connected to pin 7 (STAT2) of MCP73871 Indicates when the battery is fully charged

3.3 External Power Supply Header (J5)

To measure the power going to the WBZ351PE Module, a 1x3, 2.54 mm male pin header with shunt connector (I-MEAS, J5) is provided. A shunt resistor (R36) across the jumper is also provided, which gives a relationship between the voltage drop and current consumption. For current profiling in terms of voltage using a voltage probe, mount R36 and measure the voltage drop across the shunt resistor.

3.4 USB Connectivity using Microchip USB 2.0 Hub Controller

The WBZ351 Curiosity Board has two USB end devices: PKOB4 and MCP2200. Both these USB devices are accessible to the upstream PC via a common USB connector using the Microchip USB 2.0 High Speed Hub Controller USB2512B providing the user with more ease of use.

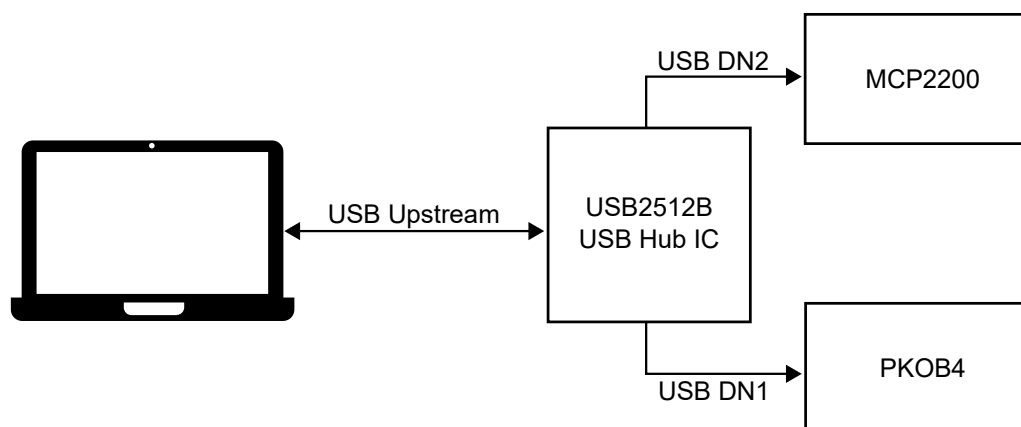
Figure 3-3. USB Connectivity using Hub Controller

After plugging the WBZ351 Curiosity Board into the upstream PC using a micro USB cable, device enumeration is as shown in the following figure for the PKOB4 and MCP2200.

Figure 3-4. Device Manager



3.5 PICKit On-Board 4 (PKoB4) and Debugger/Programmer Selection (U20)

The WBZ351 Curiosity Board includes an integrated programmer and debugger MPLAB PICKit On-Board 4 (PKoB4), a new generation of In-Circuit Debugger (ICD), which requires no additional programming/debugging tool to get started.

Features and capabilities of PKOB4:

- Connects to a Computer Through High-Speed USB 2.0 (480 Mbits/s) Cable
- Programs the Devices Using MPLAB X IDE or MPLAB IPE
- Supports Multiple Hardware and Software Breakpoints, Stopwatch and Source Code File Debugging
- Debugs the Application in Real Time
- Sets Breakpoints Based on the Internal Events
- Monitors the Internal File Registers
- Debugs at Full Speed
- Configures the Pin Drivers
- Field-Upgradable Through an MPLAB X IDE Firmware Download

- Indicates Debugger Status Through On-Board LEDs Development Board Functionality and Features

The PKOB4 on the WBZ351 Curiosity Board is intended to support programming and debugging the target device (WBZ351PE Module) through the Micro-B USB connector (J7) from the host PC. The WBZ351 Curiosity Board does not use the other PKOB4 features, such as data gateway and PICKIT4 on-board virtual COM.

By default, the on-board debugger (PKOB4) is connected to the programming pins (SWDIO and SWDCLK) of the WBZ351PE Module.

The voltage level translators are provided on signals between the PKOB4 and WBZ351PE Module for supporting target voltage from 1.9-3.6V.

Two PKOB4 LEDs indicates:

- Green (D1) – ACTIVE indicator
- Yellow (D2) – STATUS indicator

In addition, the Curiosity Board supports external debuggers, such as MPLAB ICD4 by connecting to the program/debug connector (J36).

For more details, refer to the *High-Performance Ultra-Low Power 2.4 GHz Wireless MCUs and Modules with 32-bit ARM® Cortex®-M4F, Secure Boot, Touch and 2 Msps 12-bit ADC Data Sheet (DS70005541)*.

Table 3-4. Resistor Position for Debugger Selection

On-Board PKOB4	External Debugger
R53 mounted	R53 not mounted
R62 mounted	R62 not mounted

The program/debug connector (J36) follows the standard ARM SWD 10 pinout (see [Figure 2-1](#)). Connect the MPLAB ICD4 to the debug header using the debugger adapter board (AC102015). For more details, refer to the www.microchip.com/AC102015.

Table 3-5. SWD Debug Connector Details

Pin Number of DBG Header	Pin Name	Description
1	VCC	WBZ351, also for other instances of RF module power supply
2	SWDIO	PB9, SWD programming data
3	GND	Ground
4	SWCLK	PB8, SWD programming clock
5	GND	Ground
6	SWO	PB7, optional trace output
7	NC	No connection
8	NC	No connection
9	GND	Ground
10	RESET	WBZ351 Reset NMCLR pin

3.6 USB-to-UART Serial Converter (U18)

The WBZ351 Curiosity Board has an on-board MCP2200 that acts as a USB-to-UART serial converter (U18) with hardware flow control support and enables the user through the Micro-B USB connector (J7) from the host PC. MCP2200 supports UART baud rates from 300-1000 kbps. It also provides voltage level translators on signals between the MCP2200 and WBZ351PE Module for supporting target voltage from 1.9-3.6V in case of supplying the power externally.

Table 3-6. USB Serial Converter Pin Assignment

Pin on MCP2200	Pin on WBZ351PE Module	Description
TX	PA6, SERCOM0_PAD1	UART RX pin of the WBZ351PE Module
RX	PA5, SERCOM0_PAD0	UART TX pin of the WBZ351PE Module
RTS	PB4 ⁽¹⁾ , UART_CTS	UART CTS pin of the WBZ351PE Module
CTS	PA3, UART_RTS	UART RTS pin of the WBZ351PE Module

Note:

- By default, the PB4 is connected to the XPRO header (J20). To use UART_CTS, the user must populate resistor (R3).

3.7 mikroBUS Socket (J4)

A mikroBUS socket (J4) expands the functionality of the WBZ351 Curiosity Board using the MikroElektronika Click adapter boards.

The mikroBUS socket consists of:

- Two 1x8 female headers with Serial Peripheral Interface (SPI)
- Inter-Integrated Circuit (I²C)
- Reset Pin (RST)
- Pulse Width Modulation
- Analog and interrupt lines
- 3.3V, 5V and ground power lines.

For a complete listing of the Click boards, refer to www.mikroe.com/click.

The GPIO pins for the mikroBUS sockets are assigned to route I²C, SPI peripherals and other GPIO pins as follows.

Note: Traditional Serial Communication Interface Documentation uses the terminology “Master” and “Slave”, and the equivalent Microchip terminology used in this document is “Host” and “Client”, respectively.

Table 3-7. mikroBUS Socket Pinout Details

Pin Number	Pin Name	Pin on WBZ351PE Module	Description
1	AN	PB1/AN5/CVD5	Analog-to-Digital Converter (ADC) analog input
2	RST	PB2/RST/CVD6	General purpose I/O pin
3	\overline{CS}	PA9/SERCOM1_PAD2/SPI_SS/LED2	Client select pin for SPI/General purpose I/O pin
4	SCK	PA8/SERCOM1_PAD1/SPI_SCK/RX/LED5	SPI clock
5	MISO	PA10/SERCOM1_PAD3/SPI_MISO/LED4	SPI host input client output
6	MOSI	PA7/SERCOM1_PAD0/SPI_MOSI/TX/LED3	SPI host output client input
7	+3.3V	+3V	3V power
8	GND	GND	Ground
9	GND	GND	Ground
10	+5V	+5V	5V power
11	SDA	PA13/I2C_SERCOM_PAD0/SDA	I2C data
12	SCL	PA14/I2C_SERCOM_PAD1/SCL	I2C clock
13	TX	PA7/SERCOM1_PAD0/SPI_MOSI/TX/LED3	UART TX
14	RX	PA8/SERCOM1_PAD1/SPI_SCK/RX/LED5	UART RX
15	INT	PB10/INT/PWM/LED1	Interrupt pin/General purpose I/O pin. Shared with PWM pin

.....continued

Pin Number	Pin Name	Pin on WBZ351PE Module	Description
16	PWM	PB10/INT/PWM/LED1	PWM pin/General purpose I/O pin. Shared with INT pin

Notes:

1. Both INT and PWM on the mikroBUS socket are mapped to PB10 on the WBZ351 Curiosity Board with a strapping resistor, and do not support both functions at the same time. Depopulate R120 to isolate PWM while depopulate R121 to isolate INT (for examples, refer to www.mikroe.com/stepper-2-click).
2. In the mikroBUS socket, SPI SCK and UART RX share the PA8, depopulate R123 to isolate SPI SCK and depopulate R122 to isolate UART RX.
3. In the mikroBUS socket, SPI MOSI and UART TX share the PA7, depopulate R125 to isolate SPI MOSI and depopulate R124 to isolate UART TX.

3.8 XPRO Header (J20)

The WBZ351 Curiosity Board includes one XPRO standard extension male header (XPRO header) (J20) to connect to the Microchip QT7/T9 Xplained Pro kit. The Microchip QT7 Xplained Pro kit is an extension board that enables the evaluation of self-capacitance touch using the Peripheral Touch Controller (PTC) module. For more details, refer to the *QT7 Xplained Pro Extension Kit* ([ATQT7-XPRO](#)).

Figure 3-5. WBZ351 Curiosity Board Connected to QT7 XPRO Over XPRO Header (J20)

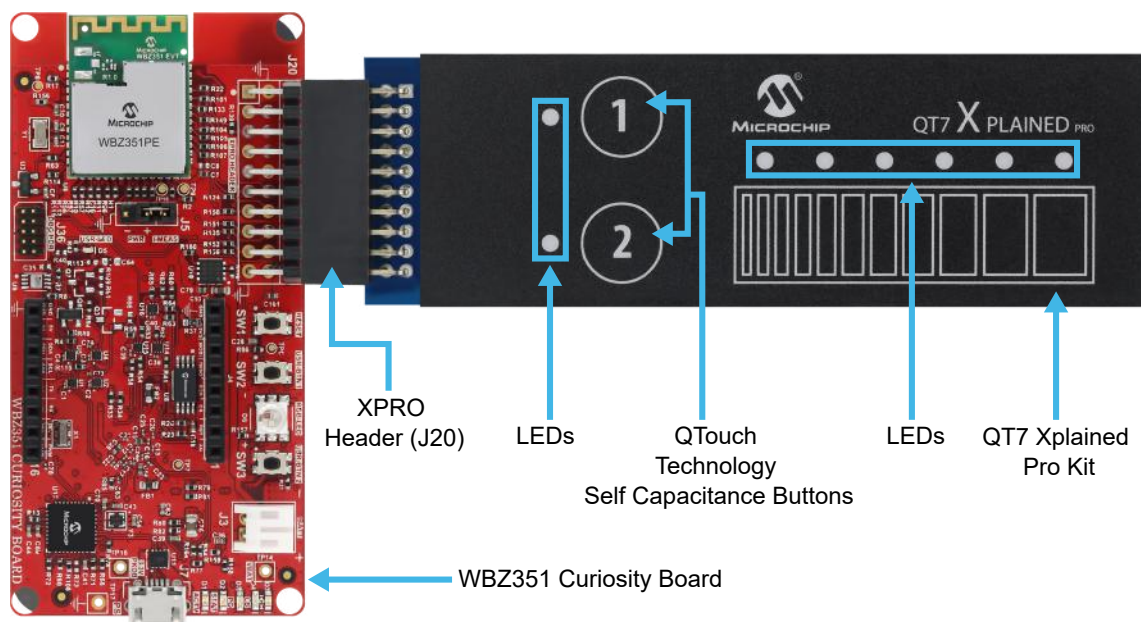

The following table provides details about the pinout definition.

Table 3-8. Pinout Definition

XPRO Header (J20) Pin	Function QT7	Function T9	Description	Mapping on WBZ351 EVB
1	ID	ID	Communication line to ID chip	—
2	GND	GND	Ground	—
3	Y-Line-5	Not connected	Y-line 5 – Connected to driven Shield	PB0/CVD4
4	Y-Line-1	Not connected	Y-line 1 – Connected to button 1	PB3/CVD7
5	LED 0	LED 2	Touch status LED for slider	PB10/INT/PWM/LED1

.....continued

XPRO Header (J20) Pin	Function QT7	Function T9	Description	Mapping on WBZ351 EVB
6	LED 6	LED 1	Touch status LED for button 1	PA4 /LED6
7	Y-Line-2	Y-Line-1	Y-line – Connected to slider/button	PB5 / CVD1
8	Y-Line-3	Y-Line-2	Y-line – Connected to slider/button	PB1/CVD5
9	Y-Line-4	Y-Line-4	Y-line – Connected to slider/button	PB2/RST/CVD6
10	Y-Line-0	Y-Line-3	Y-line – Connected to button 2	PB4/CVD0
11	LED 7	Not connected	Touch status LED for button 2	PA13/I2C_SERCOM_PAD0/SDA
12	LED 1	Not connected	Touch status LED for slider	PA14/I2C_SERCOM_PAD1
13	Not connected	Not connected	—	PA8/SERCOM1_PAD1 (UART_RX)
14	Not connected	Not connected	—	PA7/SERCOM1_PAD0 (UART_TX)
15	LED 2	LED 3	Touch status LED for slider	PA9/SERCOM1_PAD2 (SPI_SS)
16	LED 3	LED 4	Touch status LED for slider	PA7/SERCOM1_PAD0 (SPI MOSI)
17	LED 4	Not connected	Touch status LED for slider	PA10/SERCOM1_PAD3 (SPI MISO)
18	LED 5	Not connected	Touch status LED for slider	PA8/SERCOM1_PAD1 (SPI_SCK)
19	GND	GND	Ground	Ground
20	VCC	VCC	Target supply voltage	3.3V

3.9 Switches

The following switches are available on the WBZ351 Curiosity Board:

- Reset switch ([SW1](#))
- User button 1 ([SW2](#))
- User button 2 ([SW3](#))

In the Idle state, the level of the Reset switch is pulled high using the external pull-up resistor, and when the switch is pressed, it drives the level of the switch to low and resets the WBZ351PE Module.

The user-configurable switch is also pulled high using the external pull-up resistor, and when the switch is pressed, it drives the level of the switch to low and resets the WBZ351PE Module.

Table 3-9. Switches Description

Switch Name	Pin on WBZ351PE Module	Description
Reset (SW1)	NMCLR	Reset switch (SW1) connected to NMCLR pin of the WBZ351PE Module
User button 1 (SW2)	PB9/INT0	User-configurable button (SW2); configured to wake-up WBZ351PE Module from Power-down mode(s)
User button 2 (SW3)	PA4	User configurable button (SW3)

3.10 LEDs

3.10.1 User LED (D5)

One user-programmable blue indicator LED ([D5](#)) is available on the WBZ351 Curiosity Board, and this LED can be turned ON or OFF using the connected GPIO pin PB7. Drive the pin to a high level to turn OFF the LED, and drive the pin to a low level to turn ON the LED.



Important: PB7 is also the SWO pin on the WBZ351PE Module. During a programming/debug session with MPLAB X IDE, this pin is always driven low from the WBZ351PE Module, thus, making the user LED turned ON during the entire DEBUG session. The pin operates normally after exiting from the DEBUG session.

3.10.2 RGB LED (D6)

Three PWM signals from the WBZ351PE Module are connected to the RGB LED (D6) on the WBZ351 Curiosity Board.

Table 3-10. RGB LED Pin Description

Color	Pin on WBZ351PE Module
Red	PB0 ⁽¹⁾
Green	PB3
Blue	PB5 ⁽¹⁾
Notes:	
1. PB0 and PB5 are multiplexed with other functions (CVD4 and CVD1) and connected to the XPRO header (J20) to support the Out of Box (OOB) demo.	
2. The OOB demo does not support red and blue LED, and only green LED of the RGB LED (D6) is functional for the OOB demo.	

3.11 Temperature Sensor (U3)

The temperature sensor (2.3-5.5V Microchip MCP9700A) (U3) is connected to PB6 (AN2) of the WBZ351PE Module. For more details, refer to the *MCP9700A, Low-Power Linear Active Thermistor IC Data Sheet* (DS20001942).

3.12 QSPI Serial Flash (U7)

The WBZ351 Curiosity Board has an on-board 64-Mb, 2.3-3.6V Serial Quad I/O (SQI) Flash (SST26VF064B-104I/MF) (U7) memory for storage of data. A default SST26VF064B-104I/MF at power-up enables WP# and HOLD pins and disables SIO2 and SIO3 pins, allowing for SPI protocol operations without register configuration. Register configuration is required to switch to Quad I/O operation with QSPI.

Table 3-11. QSPI Flash Pin Description

QSPI Flash	Pin on WBZ351PE Module	Description
CE	PB13, QSPI_CS	QSPI chip select
SO/SIO1	PB12, QSPI_DATA1	QSPI data channel 1
WP/SIO2	PB11, QSPI_DATA2	QSPI data channel 2
VSS	GND	Ground
SI/SIO0	PA0, QSPI_DATA0	QSPI data channel 0
SCK	PA1, QSPI_SCK	QSPI clock
Hold/SIO3	PA2, QSPI_DATA3	QSPI data channel 3
VDD	VDD	VDD

3.13 32.768 kHz Secondary Oscillator

The 32.768 kHz crystal is connected to the SOSC pins (PA11 and PA12) of the WBZ351PE Module.

3.14 WBZ351PE Module

For more details on the WBZ351PE Module pinout, refer to the *High-Performance Ultra-Low Power 2.4 GHz Wireless MCUs and Modules with 32-bit ARM® Cortex®-M4F, Secure Boot, Touch and 2 Msps 12-bit ADC Data Sheet (DS70005541)*.

Note: The user can configure the Peripheral Pin Select (PPS) pins for any of the supported peripheral functions based on the end user application.

3.15 Limitations of Using Battery and External Power Supply

Battery Power:

The battery management circuit is designed for a 4.2V battery going to a downstream 3.3V regulator. When the battery voltage is near the required minimum input voltage of the regulator, it can affect the regulated output. It is advised to use a fully charged battery for evaluation, and recharge the battery as soon as the low battery output indicator is turned ON at 3.1V.

External Power Supply Header:

The WBZ351 Curiosity Board is designed by default for evaluating the WBZ351PE Module and associated peripherals with the on-board 3.3V regulator. The following limitations apply for the circuitry if the WBZ351PE Module and associated circuitry is powered from the external power supply header at other voltages:

- QSPI Serial Flash (SST26VF064B-104I/MF) (U7) – Standard operating voltage for the QSPI serial Flash is 2.3-3.6V operation
- Temperature Sensor (MPC9700A) (U3) – Standard operating voltage for the temperature sensor is 2.3-3.6V operation
- User LED (D5) – Designed for 3.3V operation; LED brightness at lower voltages is dull or no glow. To increase the emitted light level, lower the value of the series resistor (R42).
- RGB Lighting LED (D6) – VBAT net powers the RGB lightning LED. To be functional, plug in either the USB or battery power supply.

4. WBZ351 Curiosity Board Out of Box Demo

The [Out of Box demo](#) application is preprogrammed on the WBZ351 Curiosity Board. The Microchip Bluetooth Data (MBD) smartphone application has the capability to scan for Bluetooth low energy advertisements from the WBZ351 Module and to establish a connection.

The scan operation monitors the temperature sensor and the status of the green LED of the RGB LED (D6) (ON or OFF). Establishing a Bluetooth low energy connection with the WBZ351 Module enables users to control the status and brightness of the green LED of the RGB LED (D6). In addition, the user can control the green LED of the RGB LED (D6) brightness using the touch slider and button by connecting the QT7 XPRO add-on board to the XPRO header (J20) of the WBZ351 Curiosity Board.

For more details for the Out of Box (OOB) demo source code and demo guide, refer to the section *Getting Started with WBZ351 Curiosity Board* in the [PIC32CXBZ3/WBZ35 Application Developer's Guide](#).

5. Appendix A: Reference Circuit

5.1 WBZ351 Curiosity Board Reference Schematics

Figure 5-1. Power Distribution Switch for PKoB4

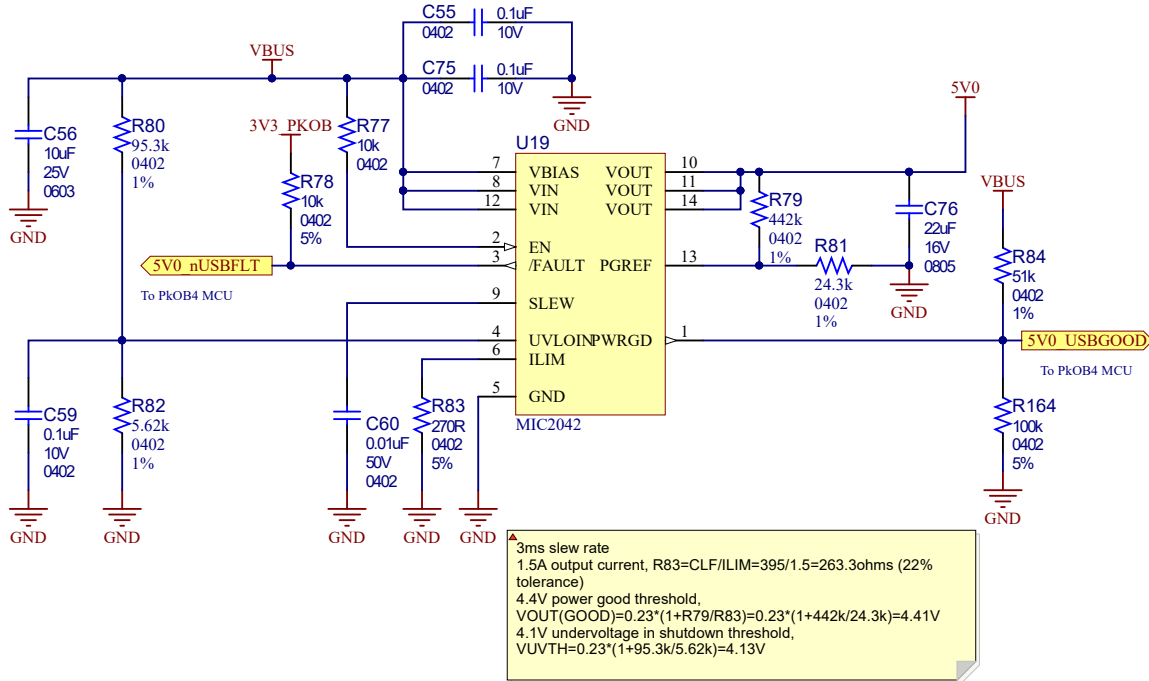

Figure 5-2. Li-Po Battery Connector/Charger

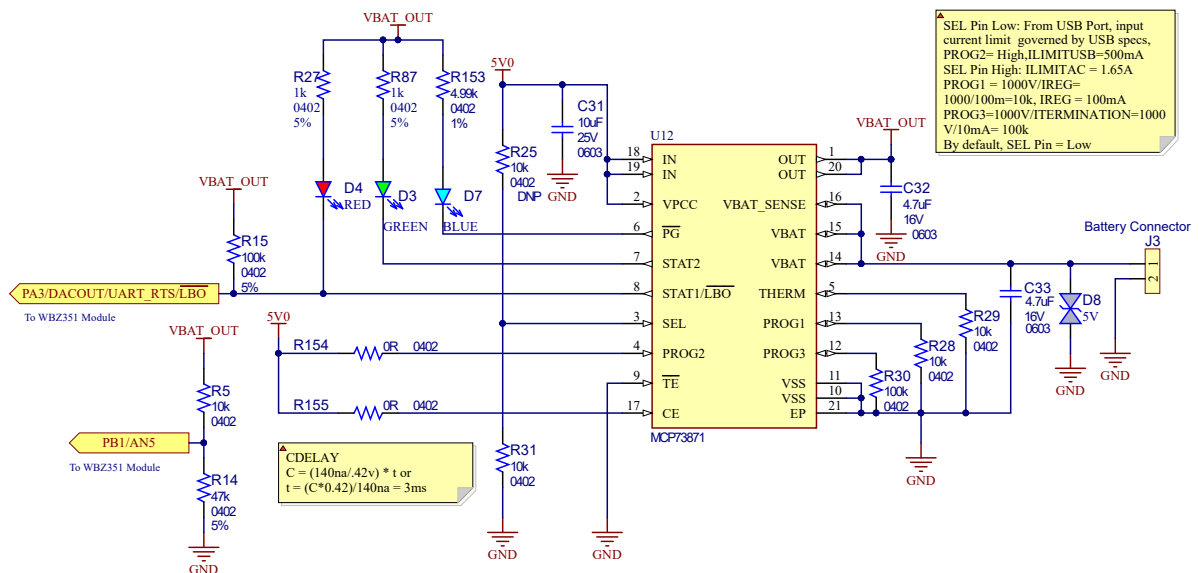

Figure 5-3. PKOB 3.3V Regulator (For SAME70 MCU)

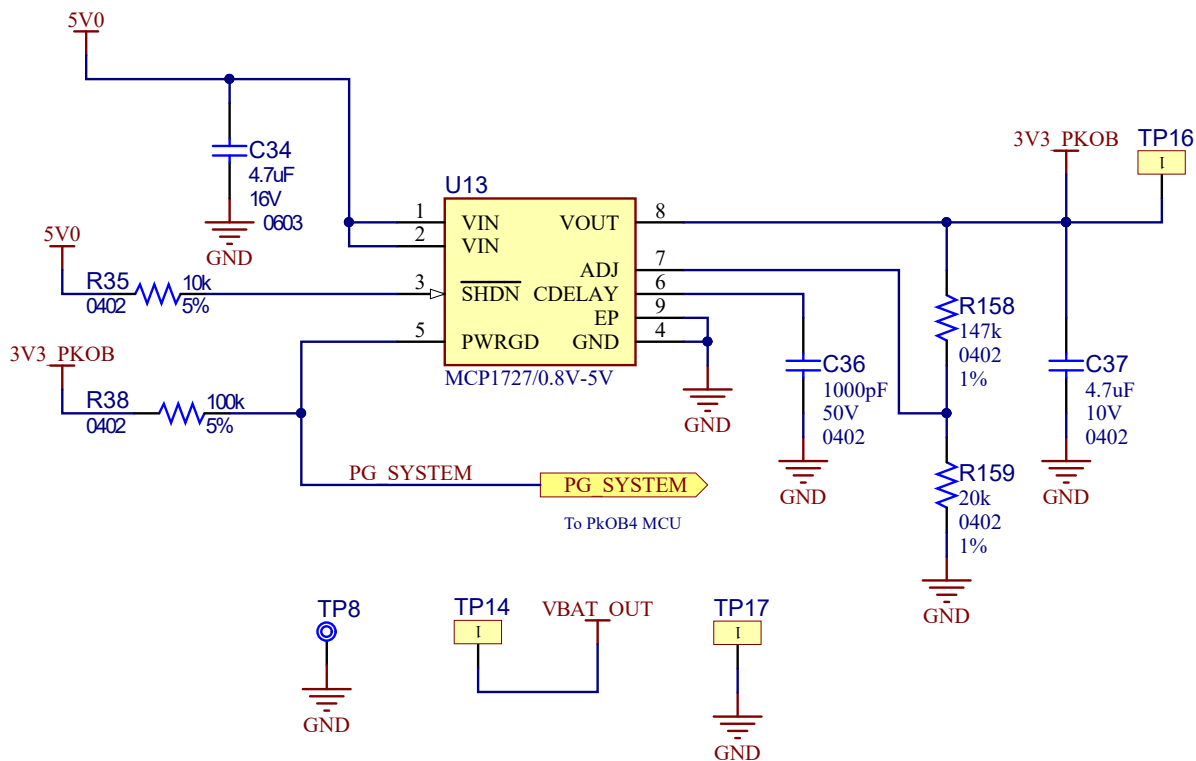

Figure 5-4. WBZ351PE Module 3.3V Regulator

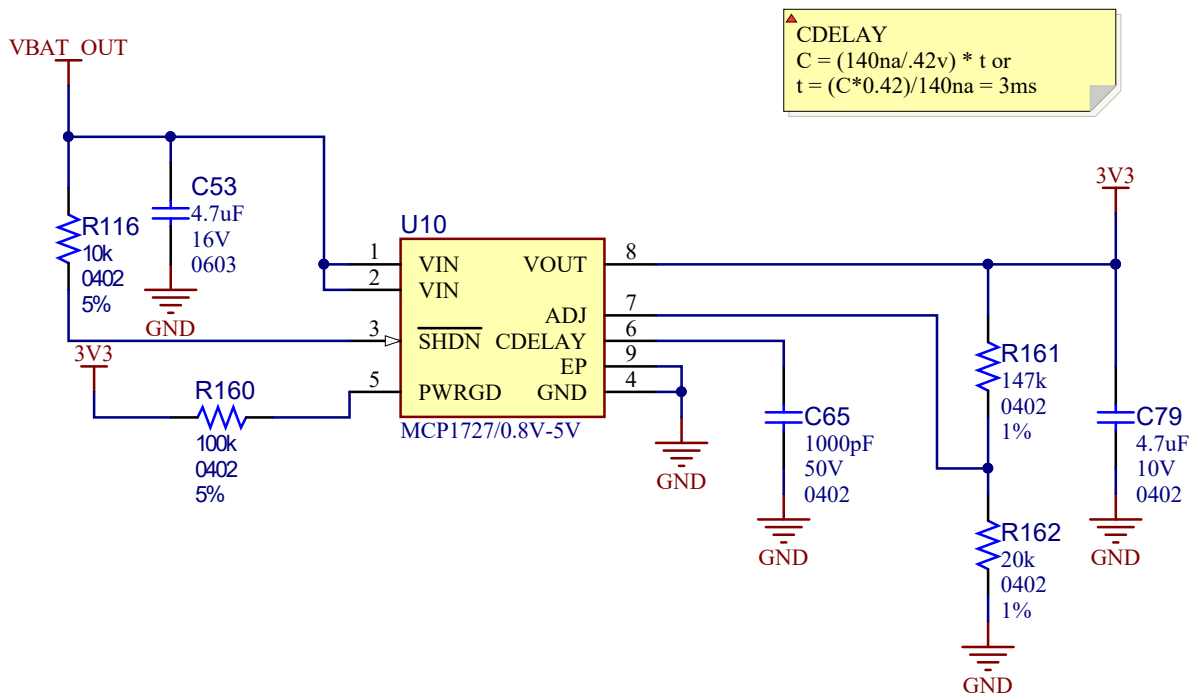

Figure 5-5. External Power Supply and Current Measurement Header

▲ For External Supply connect to J5 Pin 2 and 3.
 For on-board power (LDO) short J5 Pin1 and 2.

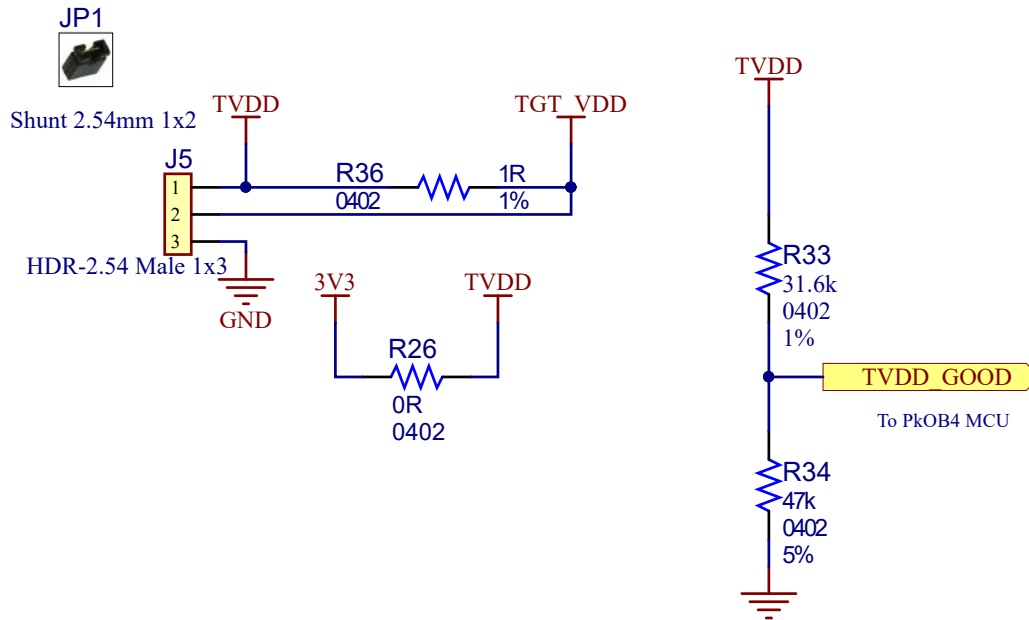

Figure 5-6. WBZ351 Interface (LGA Pads) and QSPI Flash Interface

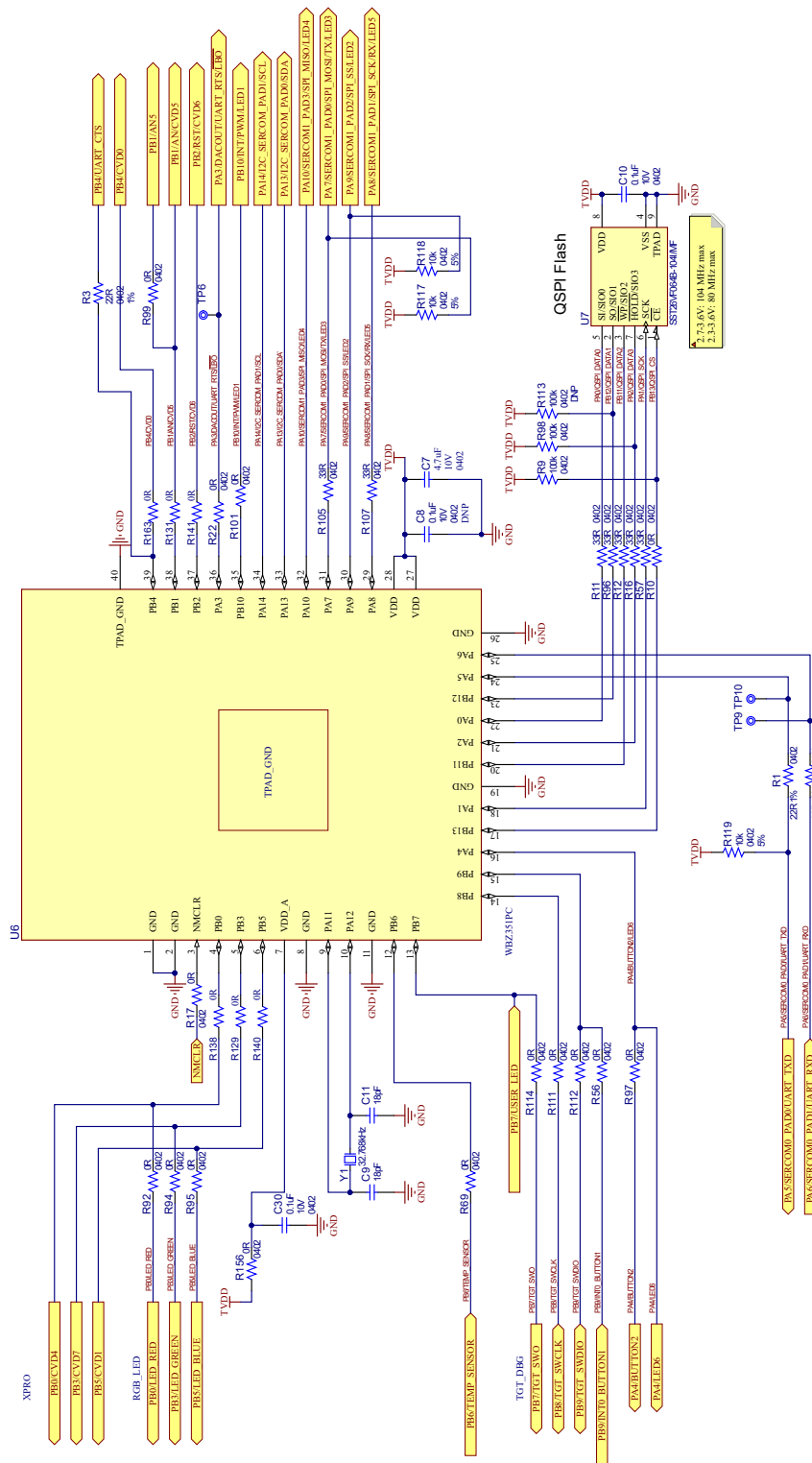

Figure 5-7. mikroBUS Click Interface and Crypto IC

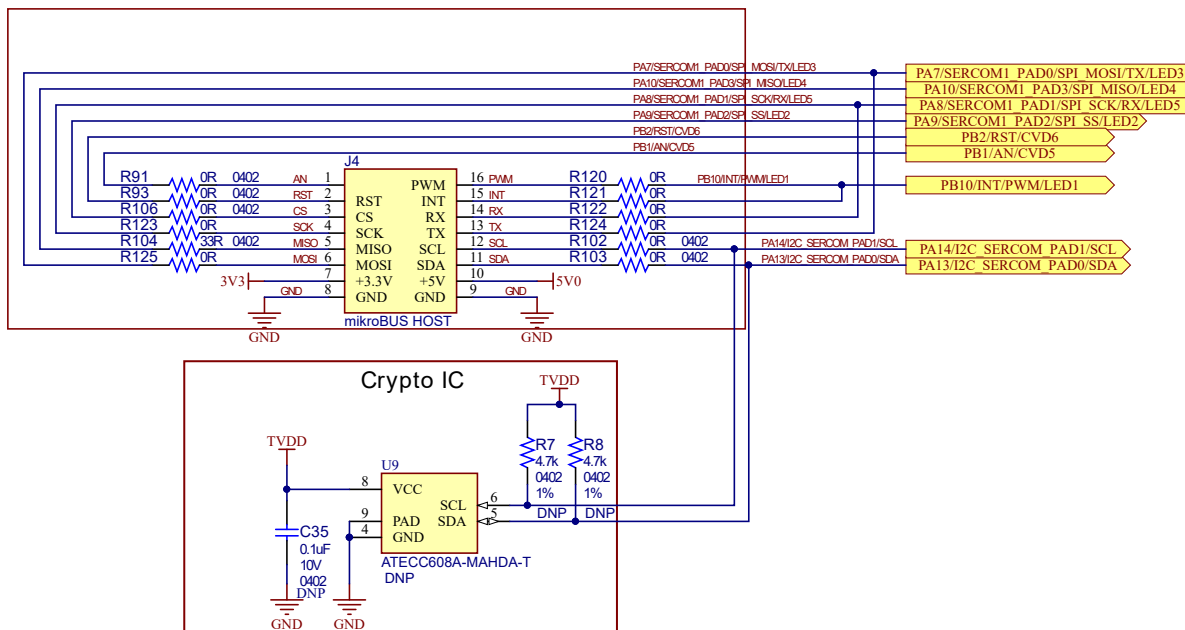

Figure 5-8. RGB LED

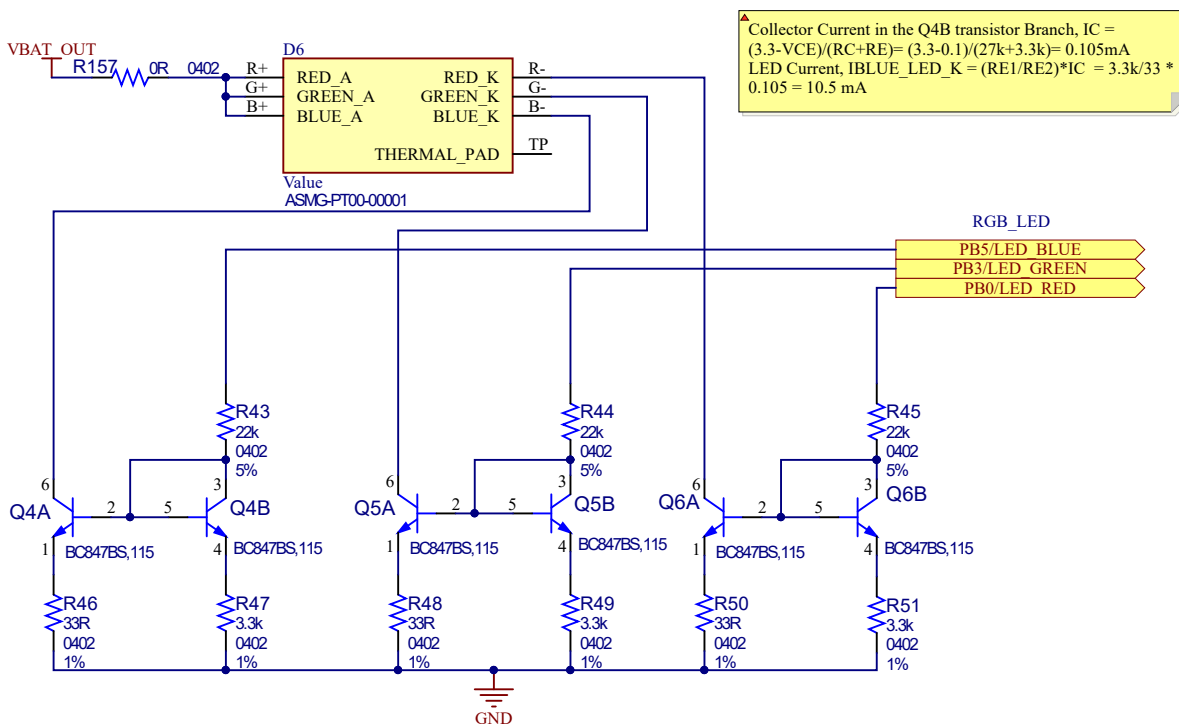

Figure 5-9. User LED

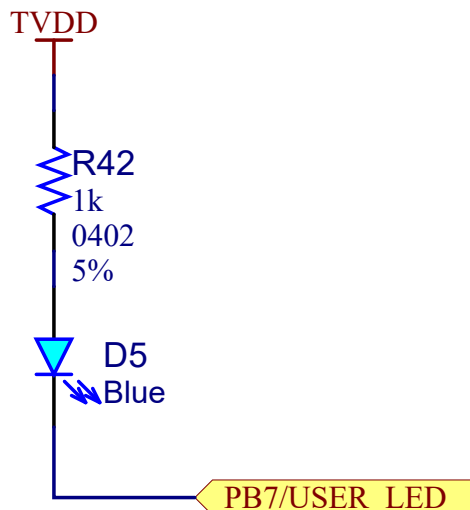

Figure 5-10. Debug Header

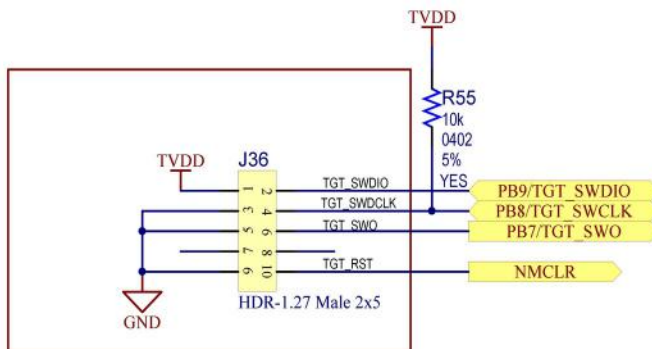

Figure 5-11. Xpro Header

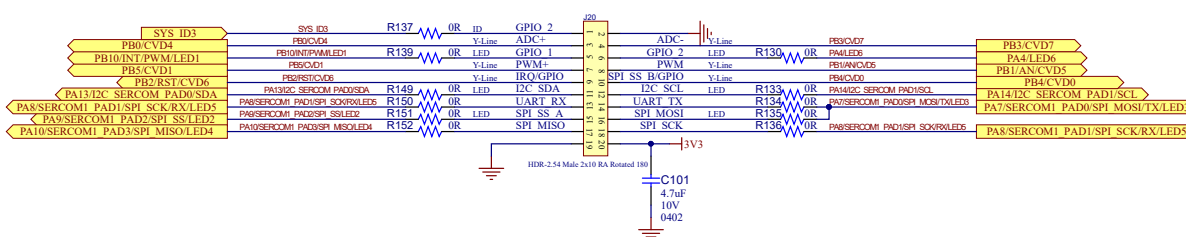

Figure 5-12. Temperature Sensor

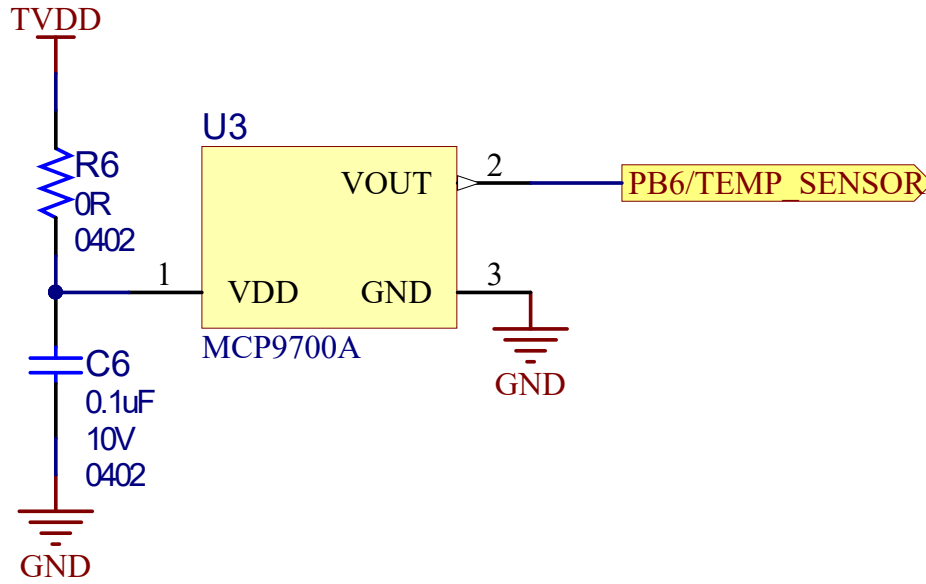

Figure 5-13. Reset Button

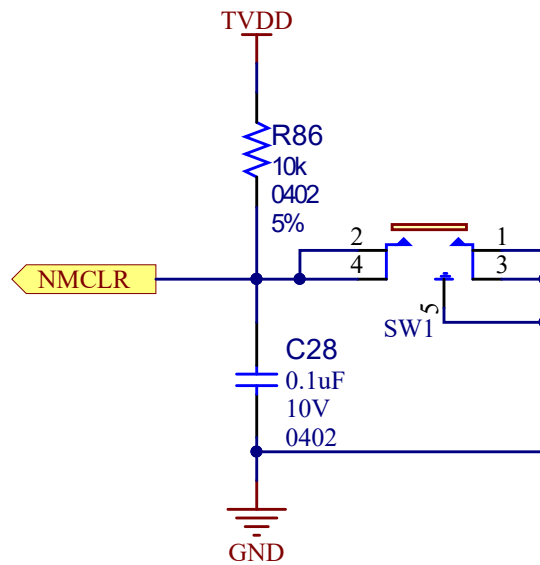

Figure 5-14. User Button 1 (Low Power)

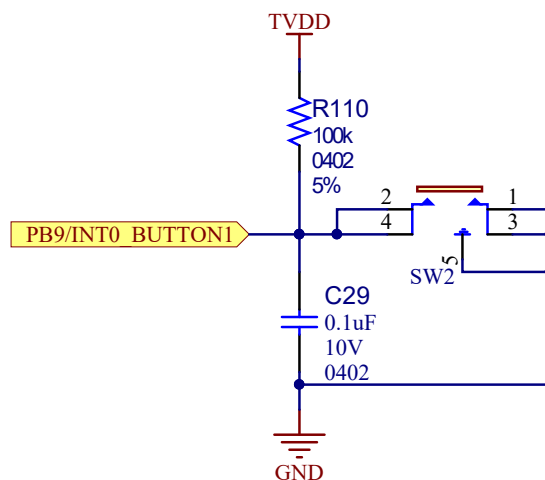

Figure 5-15. User Button 2

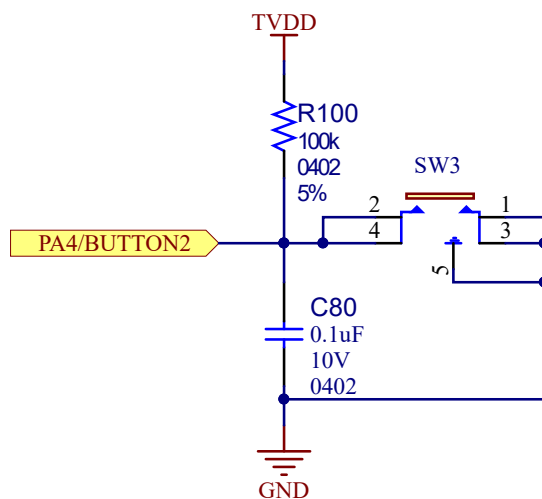

Figure 5-16. Application Virtual Comm Port

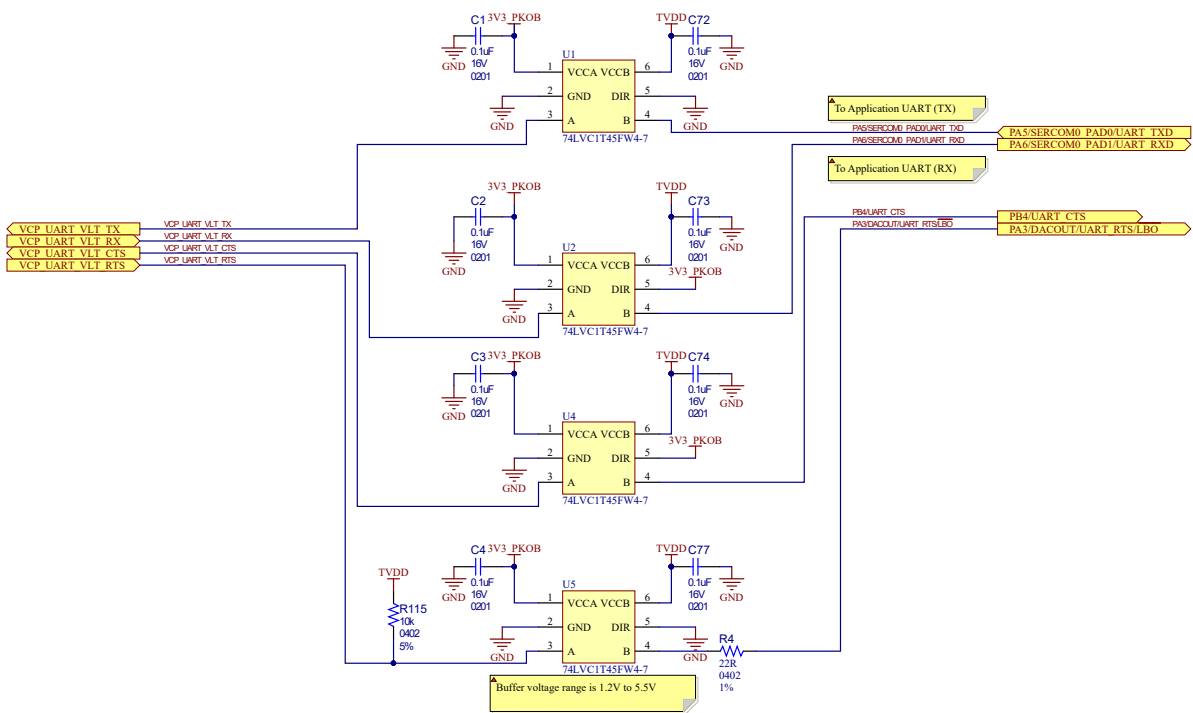

Figure 5-17. Serial Wire Debug

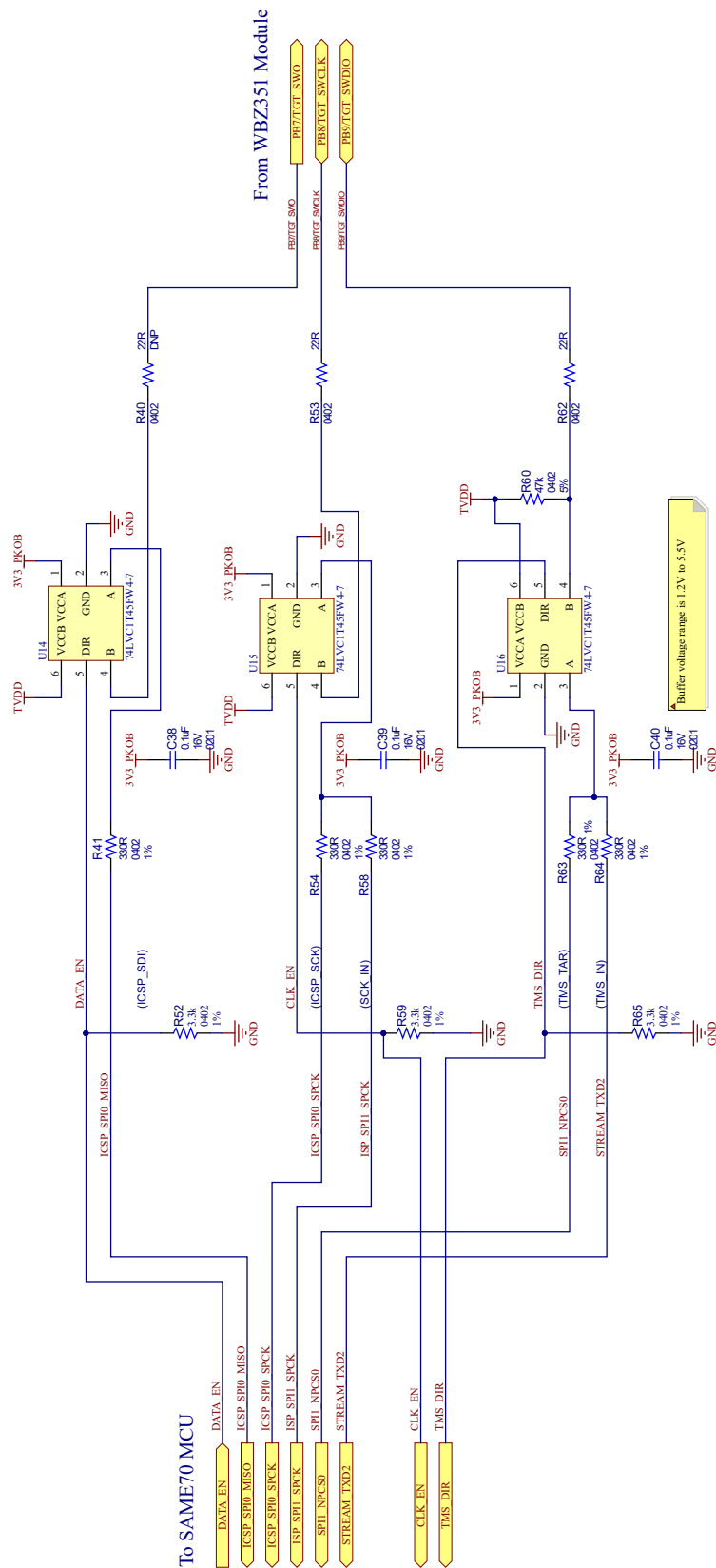

Figure 5-18. VPP Switch

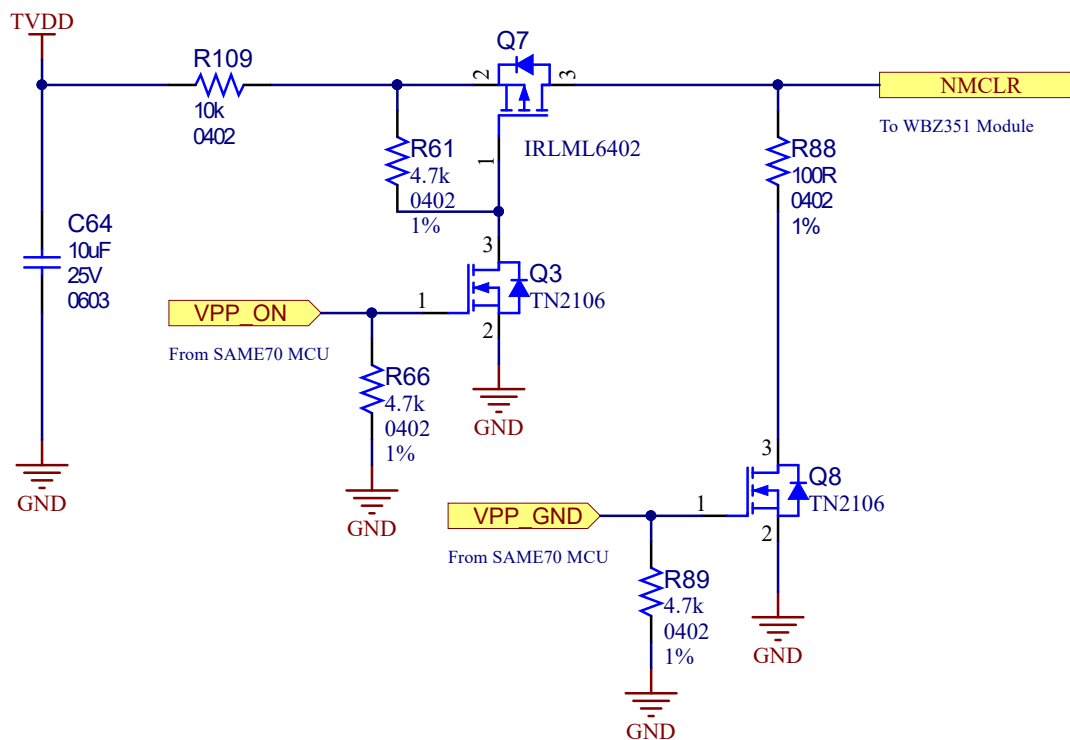

Figure 5-19. VDD Bleeder

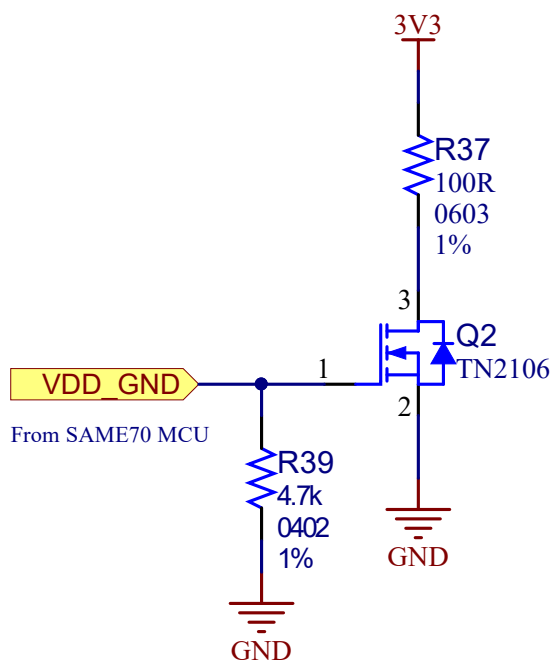

Figure 5-21. MCP2200 USB UART Converter

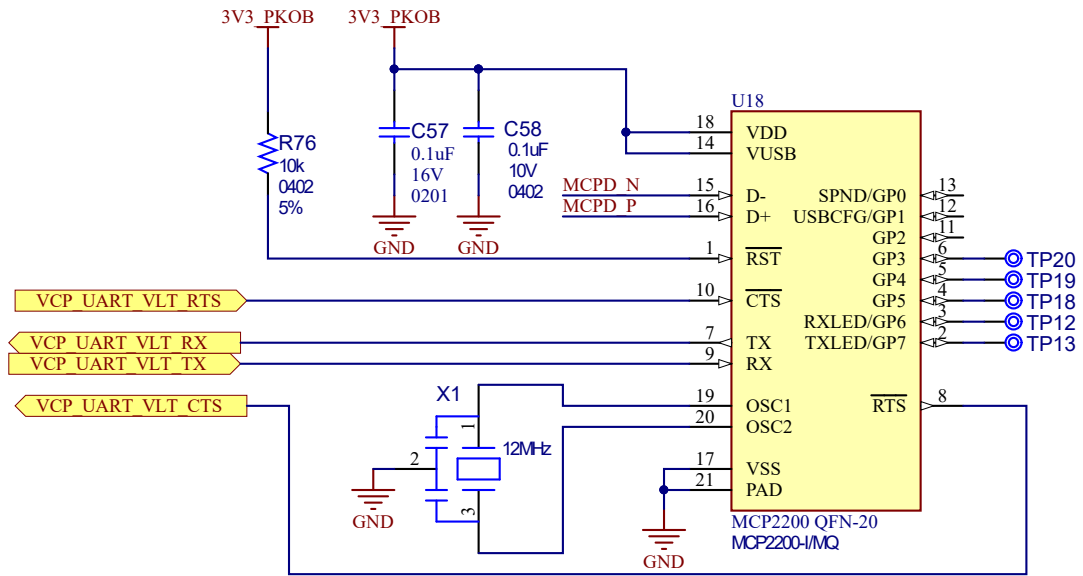

Figure 5-22. Stitching Cap

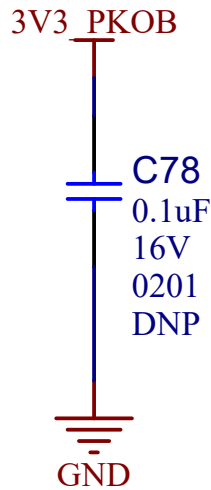

Figure 5-23. PkOb4 Main Micro 1 of 2

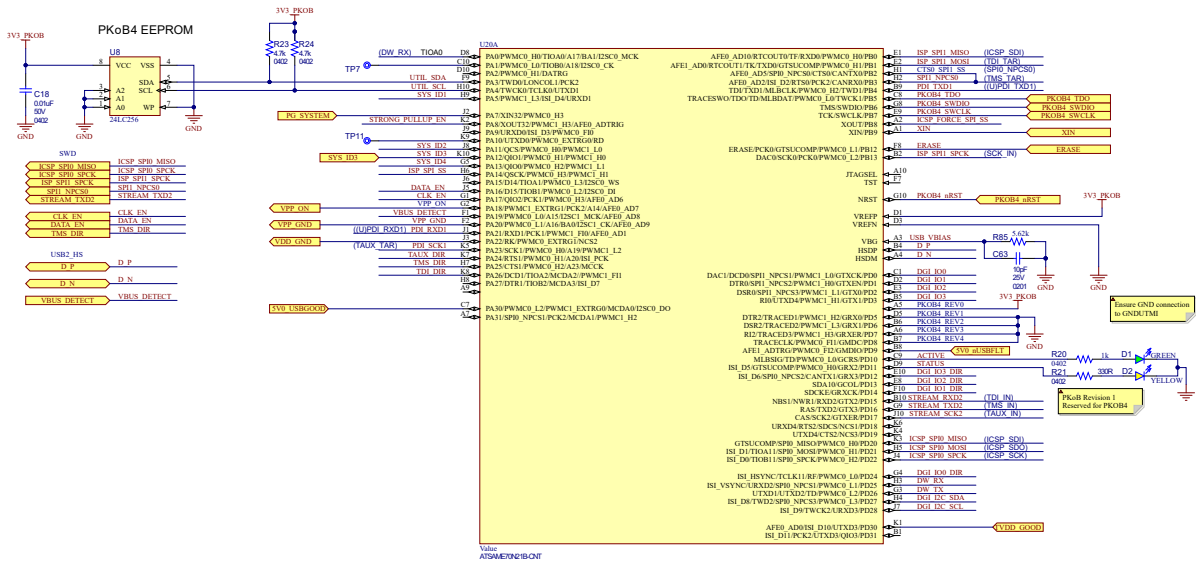
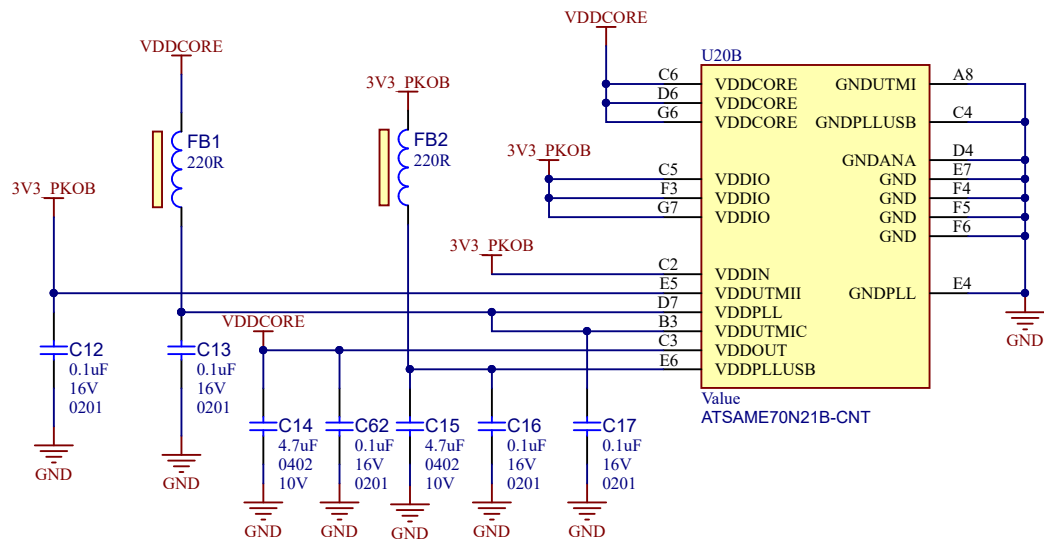

Figure 5-24. PkOb4 Main Micro 2 of 2



Either Y2 or Y5 is Populated

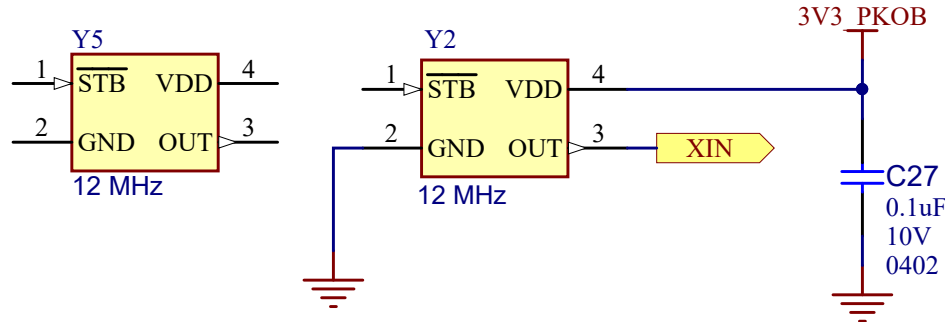

Figure 5-25. PKoB4 Debug Header

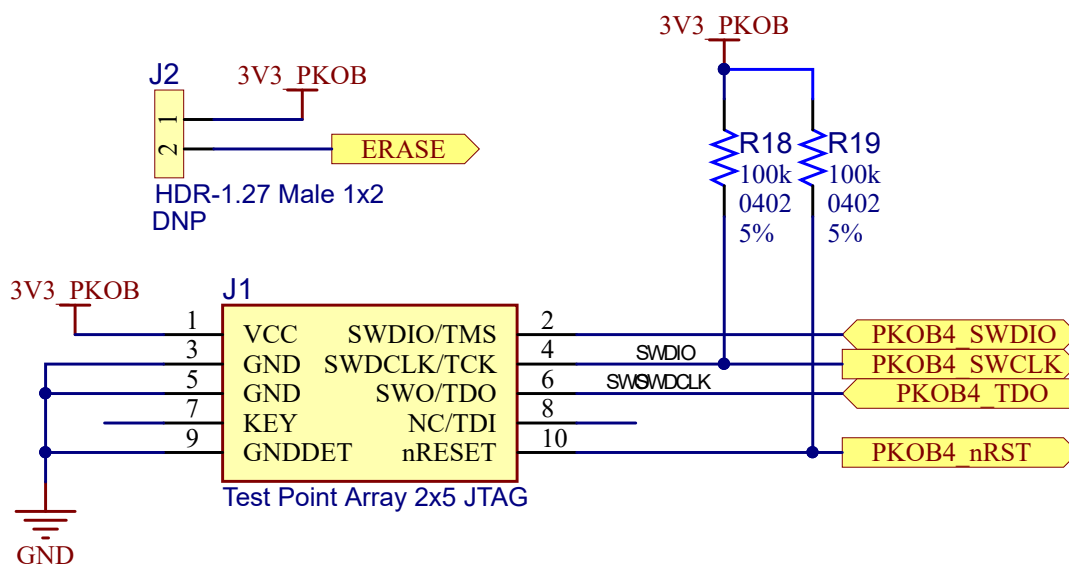

Figure 5-26. VDDIN Cap

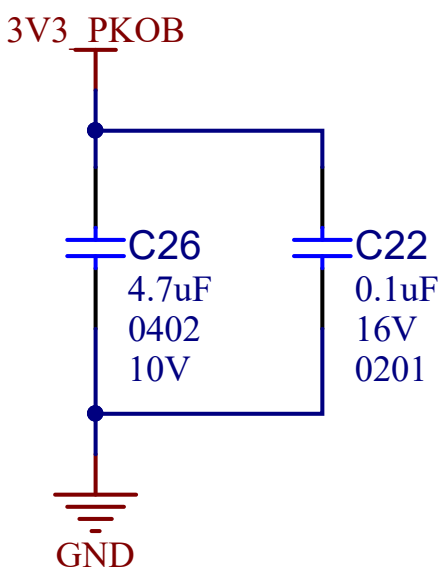

Figure 5-27. VDDIO Bypass Caps

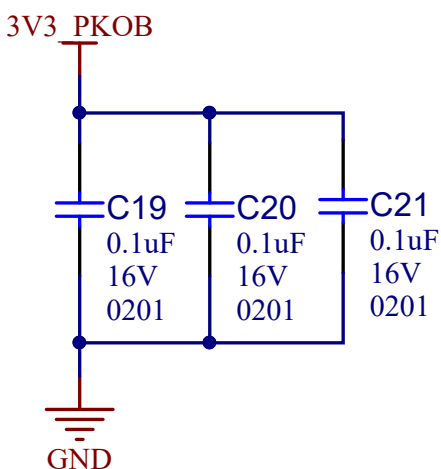
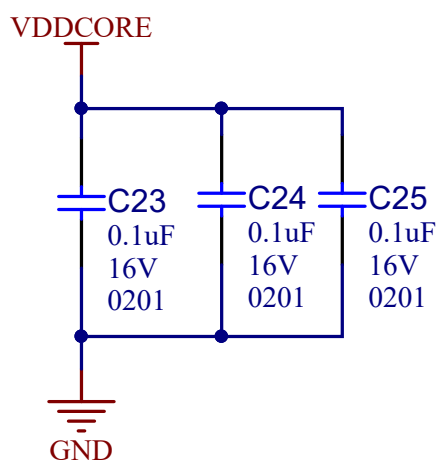

Figure 5-28. VDDCORE Bypass Caps



5.2 WBZ351 Curiosity Board Bill of Materials

For the Bill of Materials (BOM) of the WBZ351 Curiosity Board, go to the *EV19J06A* product web page.

6. Appendix B: PKOB4 Recovery Method

When the MPLAB PICkit On-Board 4 is not responding (in rare cases), the user can recover its operation by following these steps:

WARNING Only use this utility to restore the hardware tool boot firmware to its factory state. Use only if the hardware tool no longer functions on any machine.

1. With the WBZ351 Curiosity Board still being powered, short the two pads for approximately 10 seconds.

Figure 6-1. Location of Pads to Short

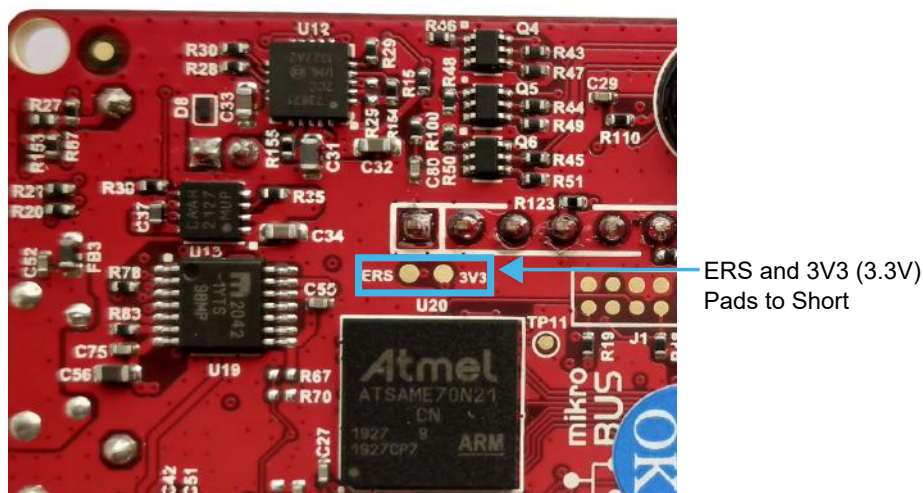

2. Open the latest version of MPLAB X. For more details, refer to [1.3. Software Prerequisites](#).
3. Go to *Debug>Hardware Tool Emergency Boot Firmware Recovery*.

Figure 6-2. Hardware Tool Emergency Boot Firmware Recovery

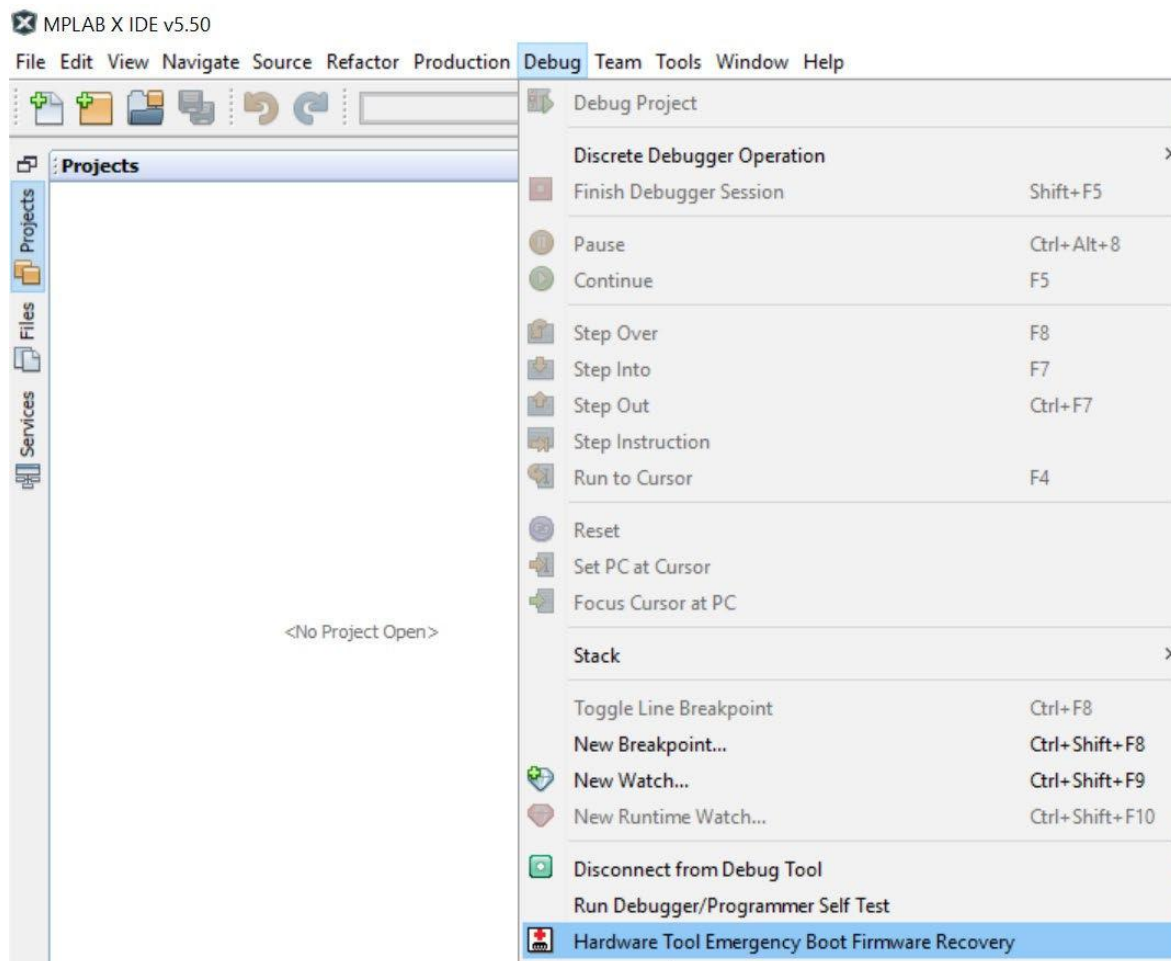

- Follow the directions on the screen. This resets the tool back to the factory conditions.
Note: For more details, refer to [How to Use the Hardware Tool Emergency Boot Firmware Recovery Utility](#).

7. Appendix: B Regulatory Approval

This equipment (WBZ351 Curiosity Board/EV19J06A) is an evaluation kit and not a finished product. It is intended for laboratory evaluation purposes only. It is not directly marketed or sold to the general public through retail; it is only sold through authorized distributors or through Microchip. Using this requires a significant engineering expertise towards understanding of the tools and relevant technology, which can be expected only from a person who is professionally trained in the technology.

Regulatory compliance settings have to follow the WBZ351PE module certifications. The following regulatory notices are to cover the requirements under the regulatory approval.

7.1 United States

The WBZ351 Curiosity Board (EV19J06A) contains the WBZ351PE module, which has received Federal Communications Commission (FCC) CFR47 Telecommunications, Part 15 Subpart C “Intentional Radiators” single-modular approval in accordance with Part 15.212 Modular Transmitter approval.

Contains FCC ID: 2ADHKWBZ351

This device complies with Part 15 of the FCC Rules. Operation is subject to the following two conditions: (1) this device may not cause harmful interference, and (2) this device must accept any interference received, including interference that may cause undesired operation.



Important: FCC Radiation Exposure Statement

This equipment complies with FCC radiation exposure limits set forth for uncontrolled environment. The antenna(s) used for this transmitter must be installed to provide a separation distance of at least 8 cm from all persons and must not be co-located or operating in conjunction with any other antenna or transmitter. This transmitter is restricted for use with the specific antenna(s) tested in this application for certification.

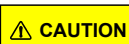

CAUTION Any changes or modifications not expressly approved by the party responsible for compliance could void the user's authority to operate this equipment.

Note: This equipment has been tested and found to comply with the limits for a Class B digital device, pursuant to part 15 of the FCC rules. These limits are designed to provide reasonable protection against harmful interference in a residential installation. This equipment generates, uses and can radiate radio frequency energy and, if not installed and used in accordance with the instructions, may cause harmful interference to radio communications. However, there is no guarantee that interference will not occur in a particular installation. If this equipment does cause harmful interference to radio or television reception, which can be determined by turning the equipment off and on, the user is encouraged to try to correct the interference by one or more of the following measures:

- Reorient or relocate the receiving antenna.
- Increase the separation between the equipment and receiver.
- Connect the equipment into an outlet on a circuit different from that to which the receiver is connected.
- Consult the dealer or an experienced radio/TV technician for help.

7.2 Canada

The WBZ351 Curiosity Board (EV19J06A) contains the WBZ351PE module, which has been certified for use in Canada under Innovation, Science and Economic Development Canada (ISED, formerly Industry Canada) Radio Standards Procedure (RSP) RSP-100, Radio Standards Specification (RSS) RSS-Gen and RSS-247.

Contains IC: 20266-WBZ351

This device contains license-exempt transmitter(s)/receiver(s) that comply with Innovation, Science and Economic Development Canada's license-exempt RSS(s). Operation is subject to the following two conditions:

1. This device may not cause interference;
2. This device must accept any interference, including interference that may cause undesired operation of the device.

L'émetteur/récepteur exempt de licence contenu dans le présent appareil est conforme aux CNR d'Innovation, Sciences et Développement économique Canada applicables aux appareils radio exempts de licence. L'exploitation est autorisée aux deux conditions suivantes:

1. L'appareil ne doit pas produire de brouillage;
2. L'appareil doit accepter tout brouillage radioélectrique subi, même si le brouillage est susceptible d'en compromettre le fonctionnement.



This equipment complies with radio frequency exposure limits set forth by Innovation, Science and Economic Development Canada for an uncontrolled environment. This equipment should be installed and operated with a minimum distance of 20 cm between the device and the user or bystanders.

Cet équipement est conforme aux limites d'exposition aux radiofréquences définies par d'Innovation, Sciences et Développement économique Canada pour un environnement non contrôlé. Cet équipement doit être installé et utilisé avec un minimum de 20 cm de distance entre le dispositif et l'utilisateur ou des tiers.

7.3 Europe

This equipment (EV19J06A) has been assessed under the Radio Equipment Directive (RED) for use in European Union countries. The product does not exceed the specified power ratings, antenna specifications and/or installation requirements as specified in the user manual. A Declaration of Conformity is issued for each of these standards and kept on file as described in Radio Equipment Directive (RED).

Simplified EU Declaration of Conformity

Hereby, Microchip Technology Inc. declares that the radio equipment type [EV19J06A] is in compliance with Directive 2014/53/EU.

The full text of the EU declaration of conformity is available at *EV19J06A* (See *Conformity Documents*).

8. Document Revision History

The revision history describes the changes that were implemented in the document. The changes are listed by revision, starting with the most current publication.

Table 8-1. Document Revision History

Revision	Date	Section	Description
A	11/2023	Document	Initial Revision

Microchip Information

The Microchip Website

Microchip provides online support via our website at www.microchip.com/. This website is used to make files and information easily available to customers. Some of the content available includes:

- **Product Support** – Data sheets and errata, application notes and sample programs, design resources, user’s guides and hardware support documents, latest software releases and archived software
- **General Technical Support** – Frequently Asked Questions (FAQs), technical support requests, online discussion groups, Microchip design partner program member listing
- **Business of Microchip** – Product selector and ordering guides, latest Microchip press releases, listing of seminars and events, listings of Microchip sales offices, distributors and factory representatives

Product Change Notification Service

Microchip’s product change notification service helps keep customers current on Microchip products. Subscribers will receive email notification whenever there are changes, updates, revisions or errata related to a specified product family or development tool of interest.

To register, go to www.microchip.com/pcn and follow the registration instructions.

Customer Support

Users of Microchip products can receive assistance through several channels:

- Distributor or Representative
- Local Sales Office
- Embedded Solutions Engineer (ESE)
- Technical Support

Customers should contact their distributor, representative or ESE for support. Local sales offices are also available to help customers. A listing of sales offices and locations is included in this document.

Technical support is available through the website at: www.microchip.com/support

Microchip Devices Code Protection Feature

Note the following details of the code protection feature on Microchip products:

- Microchip products meet the specifications contained in their particular Microchip Data Sheet.
- Microchip believes that its family of products is secure when used in the intended manner, within operating specifications, and under normal conditions.
- Microchip values and aggressively protects its intellectual property rights. Attempts to breach the code protection features of Microchip product is strictly prohibited and may violate the Digital Millennium Copyright Act.
- Neither Microchip nor any other semiconductor manufacturer can guarantee the security of its code. Code protection does not mean that we are guaranteeing the product is “unbreakable”. Code protection is constantly evolving. Microchip is committed to continuously improving the code protection features of our products.

Legal Notice

This publication and the information herein may be used only with Microchip products, including to design, test, and integrate Microchip products with your application. Use of this information in any other manner violates these terms. Information regarding device applications is provided only for your convenience and may be superseded by updates. It is your responsibility to ensure

that your application meets with your specifications. Contact your local Microchip sales office for additional support or, obtain additional support at www.microchip.com/en-us/support/design-help/client-support-services.

THIS INFORMATION IS PROVIDED BY MICROCHIP "AS IS". MICROCHIP MAKES NO REPRESENTATIONS OR WARRANTIES OF ANY KIND WHETHER EXPRESS OR IMPLIED, WRITTEN OR ORAL, STATUTORY OR OTHERWISE, RELATED TO THE INFORMATION INCLUDING BUT NOT LIMITED TO ANY IMPLIED WARRANTIES OF NON-INFRINGEMENT, MERCHANTABILITY, AND FITNESS FOR A PARTICULAR PURPOSE, OR WARRANTIES RELATED TO ITS CONDITION, QUALITY, OR PERFORMANCE.

IN NO EVENT WILL MICROCHIP BE LIABLE FOR ANY INDIRECT, SPECIAL, PUNITIVE, INCIDENTAL, OR CONSEQUENTIAL LOSS, DAMAGE, COST, OR EXPENSE OF ANY KIND WHATSOEVER RELATED TO THE INFORMATION OR ITS USE, HOWEVER CAUSED, EVEN IF MICROCHIP HAS BEEN ADVISED OF THE POSSIBILITY OR THE DAMAGES ARE FORESEEABLE. TO THE FULLEST EXTENT ALLOWED BY LAW, MICROCHIP'S TOTAL LIABILITY ON ALL CLAIMS IN ANY WAY RELATED TO THE INFORMATION OR ITS USE WILL NOT EXCEED THE AMOUNT OF FEES, IF ANY, THAT YOU HAVE PAID DIRECTLY TO MICROCHIP FOR THE INFORMATION.

Use of Microchip devices in life support and/or safety applications is entirely at the buyer's risk, and the buyer agrees to defend, indemnify and hold harmless Microchip from any and all damages, claims, suits, or expenses resulting from such use. No licenses are conveyed, implicitly or otherwise, under any Microchip intellectual property rights unless otherwise stated.

Trademarks

The Microchip name and logo, the Microchip logo, Adaptec, AVR, AVR logo, AVR Freaks, BesTime, BitCloud, CryptoMemory, CryptoRF, dsPIC, flexPWR, HELDO, IGLOO, JukeBlox, KeeLoq, Kleer, LANCheck, LinkMD, maXStylus, maXTouch, MediaLB, megaAVR, Microsemi, Microsemi logo, MOST, MOST logo, MPLAB, OptoLyzer, PIC, picoPower, PICSTART, PIC32 logo, PolarFire, Prochip Designer, QTouch, SAM-BA, SenGenuity, SpyNIC, SST, SST Logo, SuperFlash, Symmetricom, SyncServer, Tachyon, TimeSource, tinyAVR, UNI/O, Vectron, and XMEGA are registered trademarks of Microchip Technology Incorporated in the U.S.A. and other countries.

AgileSwitch, ClockWorks, The Embedded Control Solutions Company, EtherSynch, Flashtec, Hyper Speed Control, HyperLight Load, Libero, motorBench, mTouch, Powermite 3, Precision Edge, ProASIC, ProASIC Plus, ProASIC Plus logo, Quiet-Wire, SmartFusion, SyncWorld, TimeCesium, TimeHub, TimePictra, TimeProvider, and ZL are registered trademarks of Microchip Technology Incorporated in the U.S.A.

Adjacent Key Suppression, AKS, Analog-for-the-Digital Age, Any Capacitor, AnyIn, AnyOut, Augmented Switching, BlueSky, BodyCom, Clockstudio, CodeGuard, CryptoAuthentication, CryptoAutomotive, CryptoCompanion, CryptoController, dsPICDEM, dsPICDEM.net, Dynamic Average Matching, DAM, ECAN, Espresso T1S, EtherGREEN, EyeOpen, GridTime, IdealBridge, IGaT, In-Circuit Serial Programming, ICSP, INICnet, Intelligent Paralleling, IntelliMOS, Inter-Chip Connectivity, JitterBlocker, Knob-on-Display, MarginLink, maxCrypto, maxView, memBrain, Mindi, MiWi, MPASM, MPF, MPLAB Certified logo, MPLIB, MPLINK, mSiC, MultiTRAK, NetDetach, Omniscient Code Generation, PICDEM, PICDEM.net, PICkit, PICtail, Power MOS IV, Power MOS 7, PowerSmart, PureSilicon, QMatrix, REAL ICE, Ripple Blocker, RTAX, RTG4, SAM-ICE, Serial Quad I/O, simpleMAP, SimpliPHY, SmartBuffer, SmartHLS, SMART-I.S., storClad, SQI, SuperSwitcher, SuperSwitcher II, Switchtec, SynchroPHY, Total Endurance, Trusted Time, TSHARC, Turing, USBCheck, VariSense, VectorBlox, VeriPHY, ViewSpan, WiperLock, XpressConnect, and ZENA are trademarks of Microchip Technology Incorporated in the U.S.A. and other countries.

SQTP is a service mark of Microchip Technology Incorporated in the U.S.A.

The Adaptec logo, Frequency on Demand, Silicon Storage Technology, and Symmcom are registered trademarks of Microchip Technology Inc. in other countries.

GestIC is a registered trademark of Microchip Technology Germany II GmbH & Co. KG, a subsidiary of Microchip Technology Inc., in other countries.

All other trademarks mentioned herein are property of their respective companies.

© 2023, Microchip Technology Incorporated and its subsidiaries. All Rights Reserved.

ISBN: 978-1-6683-3142-2

Quality Management System

For information regarding Microchip's Quality Management Systems, please visit www.microchip.com/quality.

Worldwide Sales and Service

AMERICAS	ASIA/PACIFIC	ASIA/PACIFIC	EUROPE
<p>Corporate Office 2355 West Chandler Blvd. Chandler, AZ 85224-6199 Tel: 480-792-7200 Fax: 480-792-7277 Technical Support: www.microchip.com/support Web Address: www.microchip.com</p> <p>Atlanta Duluth, GA Tel: 678-957-9614 Fax: 678-957-1455</p> <p>Austin, TX Tel: 512-257-3370</p> <p>Boston Westborough, MA Tel: 774-760-0087 Fax: 774-760-0088</p> <p>Chicago Itasca, IL Tel: 630-285-0071 Fax: 630-285-0075</p> <p>Dallas Addison, TX Tel: 972-818-7423 Fax: 972-818-2924</p> <p>Detroit Novi, MI Tel: 248-848-4000</p> <p>Houston, TX Tel: 281-894-5983</p> <p>Indianapolis Noblesville, IN Tel: 317-773-8323 Fax: 317-773-5453 Tel: 317-536-2380</p> <p>Los Angeles Mission Viejo, CA Tel: 949-462-9523 Fax: 949-462-9608 Tel: 951-273-7800</p> <p>Raleigh, NC Tel: 919-844-7510</p> <p>New York, NY Tel: 631-435-6000</p> <p>San Jose, CA Tel: 408-735-9110 Tel: 408-436-4270</p> <p>Canada - Toronto Tel: 905-695-1980 Fax: 905-695-2078</p>	<p>Australia - Sydney Tel: 61-2-9868-6733</p> <p>China - Beijing Tel: 86-10-8569-7000</p> <p>China - Chengdu Tel: 86-28-8665-5511</p> <p>China - Chongqing Tel: 86-23-8980-9588</p> <p>China - Dongguan Tel: 86-769-8702-9880</p> <p>China - Guangzhou Tel: 86-20-8755-8029</p> <p>China - Hangzhou Tel: 86-571-8792-8115</p> <p>China - Hong Kong SAR Tel: 852-2943-5100</p> <p>China - Nanjing Tel: 86-25-8473-2460</p> <p>China - Qingdao Tel: 86-532-8502-7355</p> <p>China - Shanghai Tel: 86-21-3326-8000</p> <p>China - Shenyang Tel: 86-24-2334-2829</p> <p>China - Shenzhen Tel: 86-755-8864-2200</p> <p>China - Suzhou Tel: 86-186-6233-1526</p> <p>China - Wuhan Tel: 86-27-5980-5300</p> <p>China - Xian Tel: 86-29-8833-7252</p> <p>China - Xiamen Tel: 86-592-2388138</p> <p>China - Zhuhai Tel: 86-756-3210040</p>	<p>India - Bangalore Tel: 91-80-3090-4444</p> <p>India - New Delhi Tel: 91-11-4160-8631</p> <p>India - Pune Tel: 91-20-4121-0141</p> <p>Japan - Osaka Tel: 81-6-6152-7160</p> <p>Japan - Tokyo Tel: 81-3-6880-3770</p> <p>Korea - Daegu Tel: 82-53-744-4301</p> <p>Korea - Seoul Tel: 82-2-554-7200</p> <p>Malaysia - Kuala Lumpur Tel: 60-3-7651-7906</p> <p>Malaysia - Penang Tel: 60-4-227-8870</p> <p>Philippines - Manila Tel: 63-2-634-9065</p> <p>Singapore Tel: 65-6334-8870</p> <p>Taiwan - Hsin Chu Tel: 886-3-577-8366</p> <p>Taiwan - Kaohsiung Tel: 886-7-213-7830</p> <p>Taiwan - Taipei Tel: 886-2-2508-8600</p> <p>Thailand - Bangkok Tel: 66-2-694-1351</p> <p>Vietnam - Ho Chi Minh Tel: 84-28-5448-2100</p>	<p>Austria - Wels Tel: 43-7242-2244-39 Fax: 43-7242-2244-393</p> <p>Denmark - Copenhagen Tel: 45-4485-5910 Fax: 45-4485-2829</p> <p>Finland - Espoo Tel: 358-9-4520-820</p> <p>France - Paris Tel: 33-1-69-53-63-20 Fax: 33-1-69-30-90-79</p> <p>Germany - Garching Tel: 49-8931-9700</p> <p>Germany - Haan Tel: 49-2129-3766400</p> <p>Germany - Heilbronn Tel: 49-7131-72400</p> <p>Germany - Karlsruhe Tel: 49-721-625370</p> <p>Germany - Munich Tel: 49-89-627-144-0 Fax: 49-89-627-144-44</p> <p>Germany - Rosenheim Tel: 49-8031-354-560</p> <p>Israel - Ra'anana Tel: 972-9-744-7705</p> <p>Italy - Milan Tel: 39-0331-742611 Fax: 39-0331-466781</p> <p>Italy - Padova Tel: 39-049-7625286</p> <p>Netherlands - Drunen Tel: 31-416-690399 Fax: 31-416-690340</p> <p>Norway - Trondheim Tel: 47-72884388</p> <p>Poland - Warsaw Tel: 48-22-3325737</p> <p>Romania - Bucharest Tel: 40-21-407-87-50</p> <p>Spain - Madrid Tel: 34-91-708-08-90 Fax: 34-91-708-08-91</p> <p>Sweden - Gothenberg Tel: 46-31-704-60-40</p> <p>Sweden - Stockholm Tel: 46-8-5090-4654</p> <p>UK - Wokingham Tel: 44-118-921-5800 Fax: 44-118-921-5820</p>