

Introduction [\(Ask a Question\)](#)

The PIC64GX1000 Curiosity kit (CURIOSITY-PIC64GX1000-KIT) is an RoHS-compliant, cost-optimized kit that enables you to evaluate features of the PIC64GX1000 device. The low-cost PIC64GX1000 Curiosity kit is a minimalistic board design that is directed to provide boards with the lowest possible cost to customers.

The following image highlights the top-view of the PIC64GX1000 Curiosity kit.

Figure 1. Board Callout (Top-View)

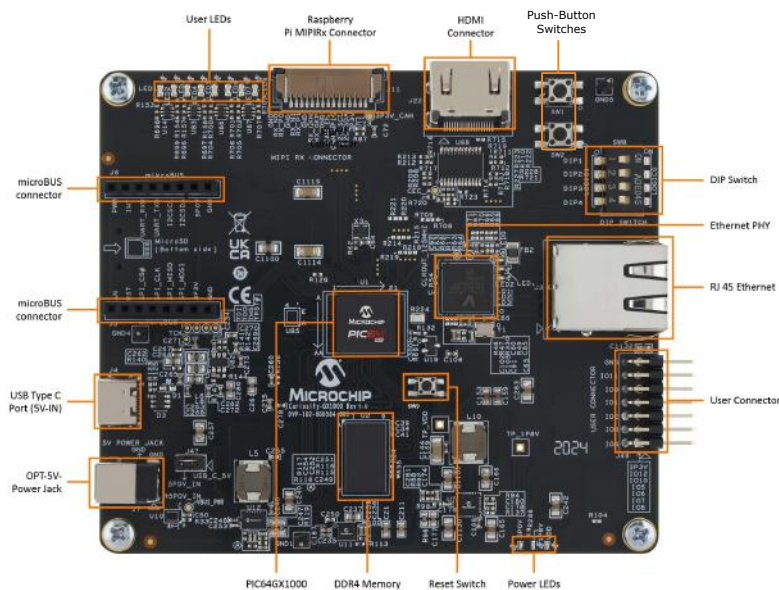

The following image highlights the bottom-view of the PIC64GX1000 Curiosity kit.

Figure 2. Board Callout (Bottom-View)

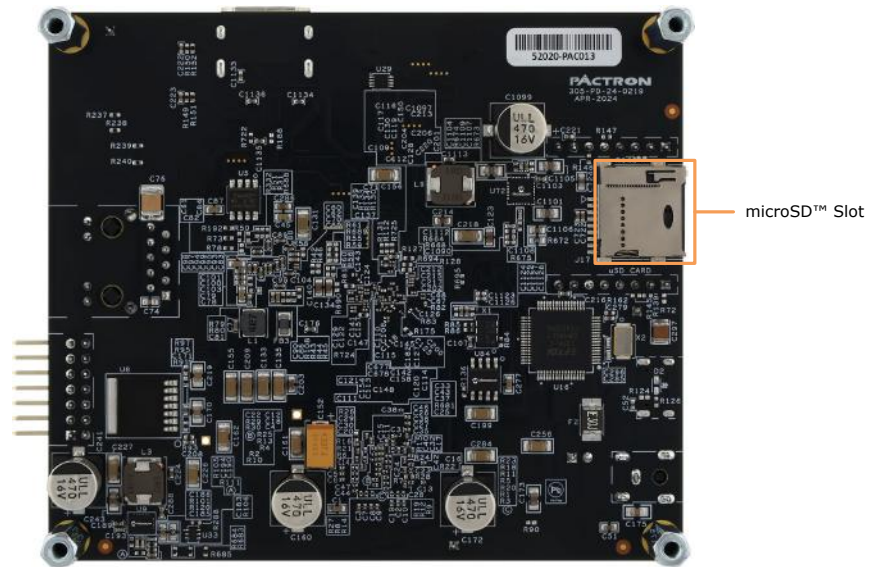

For more information about the PIC64GX1000 Curiosity kit, see the [CURIOSITY-PIC64GX1000-KIT](#) page.

Table of Contents

Introduction.....	1
1. Getting Started.....	4
1.1. Kit Contents.....	4
1.2. Block Diagram.....	4
1.3. Board Overview.....	4
1.4. Handling the Board.....	5
1.5. Operating Temperature.....	6
1.6. Powering Up the Board.....	6
2. Installation and Settings.....	7
2.1. Software and Licensing.....	7
2.2. Hardware Settings.....	7
3. Board Components and Operation.....	10
3.1. DDR4 Memory Interface.....	10
3.2. microSD Interface.....	10
3.3. Display Interface.....	10
3.4. Communications Interfaces.....	10
3.5. Expansion Capabilities.....	10
3.6. Debug Circuitry.....	11
3.7. Programming Scheme.....	11
3.8. Form Factor.....	11
3.9. System Reset.....	11
3.10. 50 MHz Oscillator.....	12
3.11. 125 MHz Oscillator.....	12
3.12. Pin List.....	12
4. Board Components Placement.....	13
Revision History.....	14
Microchip Information.....	15
Trademarks.....	15
Legal Notice.....	15
Microchip Devices Code Protection Feature.....	15

1. Getting Started

The PIC64GX1000 Curiosity kit supports the following interfaces:

- microSD™ card
- DDR4™
- SGMII
- USB-UART
- mikroBUS™
- HDMI

The PIC64GX device is programmed using the on-board FlashPro5 programmer.

1.1. Kit Contents [\(Ask a Question\)](#)

The following table lists the contents of the PIC64GX1000 Curiosity kit.

Table 1.1. Kit Contents

Item	Quantity
PIC64GX1000 Curiosity kit board with a PIC64GX1000 device	1
USB 2.0 Cable C Male to C Male 3.28' (1.00m) Shielded	1
SanDisk Ultra microSD™ UHS-I Card 32GB, 120MB/s R	1
Quickstart card	1

1.2. Block Diagram [\(Ask a Question\)](#)

The following block diagram shows the key components of the PIC64GX1000 Curiosity kit.

Figure 1.1. Block Diagram

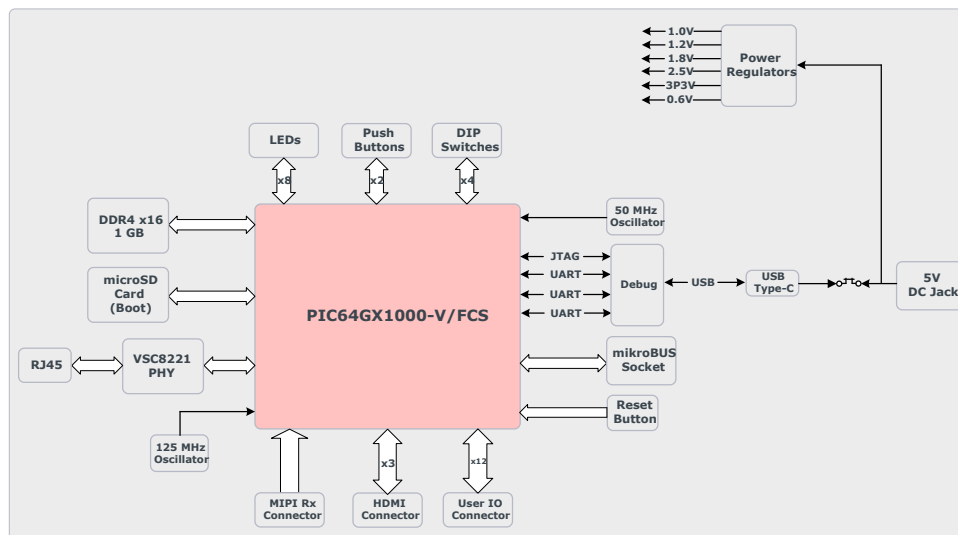

1.3. Board Overview [\(Ask a Question\)](#)

The PIC64GX1000 Curiosity kit features a PIC64GX1000-V/FCS device. The kit supports the following capabilities:

- VSC8221 with an RJ45 connector for 10/100/1000 Mbps Ethernet

- DDR4 memory
- microSD card interface
- HDMI 1.4 interface
- mikroBUS expansion port
- User IO connector

The following table lists the key components of the PIC64GX1000 Curiosity kit.

Table 1.2. Board Components

Component	Label on Board	Description
Featured Device		
PIC64GX1000-V/FCS	U1	See DS50003724, PIC64GX1000 64-bit Microprocessor Datasheet on the PIC64GX1000 page.
Power Supply		
5V/3A power supply (USB Type-C)	J4	The PIC64GX1000 Curiosity kit receives power from the USB Type-C port (J4) or the 5V DC Jack (J7). The J47 jumper setting determines which power source is used. See the Jumper Settings section.
5V DC Jack	J7	
Clocks		
50 MHz oscillator	X3	50 MHz clock oscillator with single-ended output.
125 MHz Oscillator	X1	125 MHz oscillator (differential LVDS output) which is the input to the SGMII Reference clock.
Programming and Debugging		
Embedded FlashPro5 (eFP5)	U16	On-board FlashPro5 to program and debug the device through USB-to-JTAG channel
Communication Interfaces		
Gigabit Ethernet	J3	Ethernet (RJ45) jack with built-in magnetics interfacing with VSC8221 in SGMII mode.
USB-UART	U16	FT4232HL is a USB to quad UART bridge controller. This device supports 3 UART interfaces on the PIC64GX1000 Curiosity board.
HDMI Interface	J22	Supports the HDMI 1.4 data rate.
Memory Chips		
DDR4	U2	MT40A512M16TB-062E: R is used for DDR4 interface.
microSD™ card	J17	microSD connector
General Purpose I/O		
Debug push-buttons	SW1 to SW2	For debugging
Reset push-button	SW9	For system reset
Dip Switches	SW8	Four dip switches for debugging
Light Emitting Diodes (LEDs)	LED1 to LED8	Eight active-high LEDs are available for debugging.
Expansion Interfaces		
mikroBUS™	J5 and J6	mikroBus connector.
Raspberry Pi MIPI RX Connector	J11	Facilitates interfacing with the MIPI CSI-2 camera module
User IO Connector	J49	A 14-pin User IO Connector (x12 IOs)

1.4. Handling the Board [\(Ask a Question\)](#)

To avoid damage, handle the PIC64GX1000 Curiosity board with Electrostatic Discharge (ESD) precautions. For information about handling the board with ESD precautions, see [Understanding Product Handling and ESD Precautions](#).

1.5. Operating Temperature [\(Ask a Question\)](#)

To be updated in a future revision.

1.6. Powering Up the Board [\(Ask a Question\)](#)

The PIC64GX1000 Curiosity kit receives power from the Type-C Port (J4) or the 5V DC Jack (J7). The J47 jumper setting determines which power source is used, see [Jumper Settings](#). The board receives the power from Type-C port J4 (as the J47 jumper 1 and 2 pins are closed) by default. To use the 5V DC Jack (J7) for turning on the board, the pins 1 and 2 of the J47 jumper must be open.

To power up the board, connect the Cable C Male to C Male cable from the USB Type-C port (J4) on the kit to the Type-C compatible (5V, 3A) port on the Host PC. The power status LEDs 5P0V, VDD, and 1P8V glow indicating that the board is turned on.



Important: It is recommended to use a laptop or PC USB port to power up the PIC64GX1000 Curiosity kit. By limiting the power input to laptop or PC USB ports, we can ensure that the kit operates optimally without causing any compatibility issues. The power is not tested using different docking station USB ports.

2. Installation and Settings

This section provides information about the software and hardware settings required to run the pre-programmed demo design on the PIC64GX1000 Curiosity kit.

2.1. Software and Licensing [\(Ask a Question\)](#)

The development tools, which you need to work with the PIC64GX1000 Curiosity kit are free.

The following list provides the tools needed for all platforms:

- Visual Studio Code (VSCode)
The following extensions are needed:
 - C/C++ VSCode extension: Go to VSCode extension marketplace and search for `ms-vscode.cpptools`.
 - Embedded Tools VSCode extension: Go to VSCode extension marketplace and search for `ms-vscode.vscode-embedded-tools`.
 - CMake VSCode extension: Go to VSCode extension marketplace and search for `twxs.cmake`.
- Git
 - Version 2.32.0.windows.1 or later if using Windows
 - Version 2.34.1 or later if using Linux
- Python 3.8 or later
- CMake 3.27.1 or later
- Windows specific tools:
 - Download and install `UsbDriverTool` from [USB driver installer for FTDI and Libusb drivers](#) page
- Linux specific tools:
 - `libusb-1.0`
To install `libusb-1.0`, use `sudo apt install libusb-1.0-0-dev` command.
 - `libftdi`
To install `libftdi`, use the `sudo apt install libftdi*` command.
 - `libhidapi`
To install `libhidapi`, use the `sudo apt install libhidapi-*` command.
 - `unzip`
To install `unzip`, use the `sudo apt install unzip` command.

2.2. Hardware Settings [\(Ask a Question\)](#)

This section provides information about jumper settings, test points, and Power LEDs available on the PIC64GX1000 Curiosity kit.

2.2.1. Jumper Settings [\(Ask a Question\)](#)

Connect the jumpers according to the settings specified in the following table.

Table 2.1. Jumper Settings

Jumper	Description	Pin	Default Setting
J47	Jumper to select the power source for the board	<ul style="list-style-type: none"> • Close pins 1 and 2 to receive power from the USB Type-C port (J4). • Open pins 1 and 2 to receive power from the 5V DC Jack (J7). 	1 and 2 closed

2.2.2. Power Supply LEDs [\(Ask a Question\)](#)

The following table lists the power supply LEDs available on the PIC64GX1000 Curiosity kit.

Table 2.2. Power Supply LEDs

LED	Description
VDD	1V rail (Core voltage)
1P8V	1.8V rail
5P0V	5V rail

2.2.3. Test Points [\(Ask a Question\)](#)

The following table lists the test points available on the PIC64GX1000 Curiosity kit.

Table 2.3. Test Points

Test Point	Description
GND1	Test point for GND
GND4	Test point for GND
GND5	Test point for GND
TP_VDD	Test point for 1V (core voltage rail)
TP_1P8V	Test point for 1.8V

2.2.4. Power Sources [\(Ask a Question\)](#)

The PIC64GX1000 Curiosity kit uses Microchip power supply devices. For more information about these power supply devices, see Microchip's [Power Management Devices](#). The following table lists the key voltage rails required for a normal operation of the kit.

Table 2.4. I/O Voltage Rails

Bank	I/O Rail	Voltage
Bank 1	VDDI1	3.3V
Bank 2	3P3V	3.3V
Bank 3 (JTAG)	3P3V	3.3V
Bank 4 (SD)	1P8V	1.8V
Bank 5 (SGMII)	VDDI5	3.3V
Bank 6 (DDR)	1P2V_DDR4	1.2V

The following figure shows 5V, 3.3V, 2.5V, 1.8V, 1.2V, and 1.0V (VDD) voltage rails available on the PIC64GX1000 Curiosity kit.

Figure 2.1. Power Supply Topology

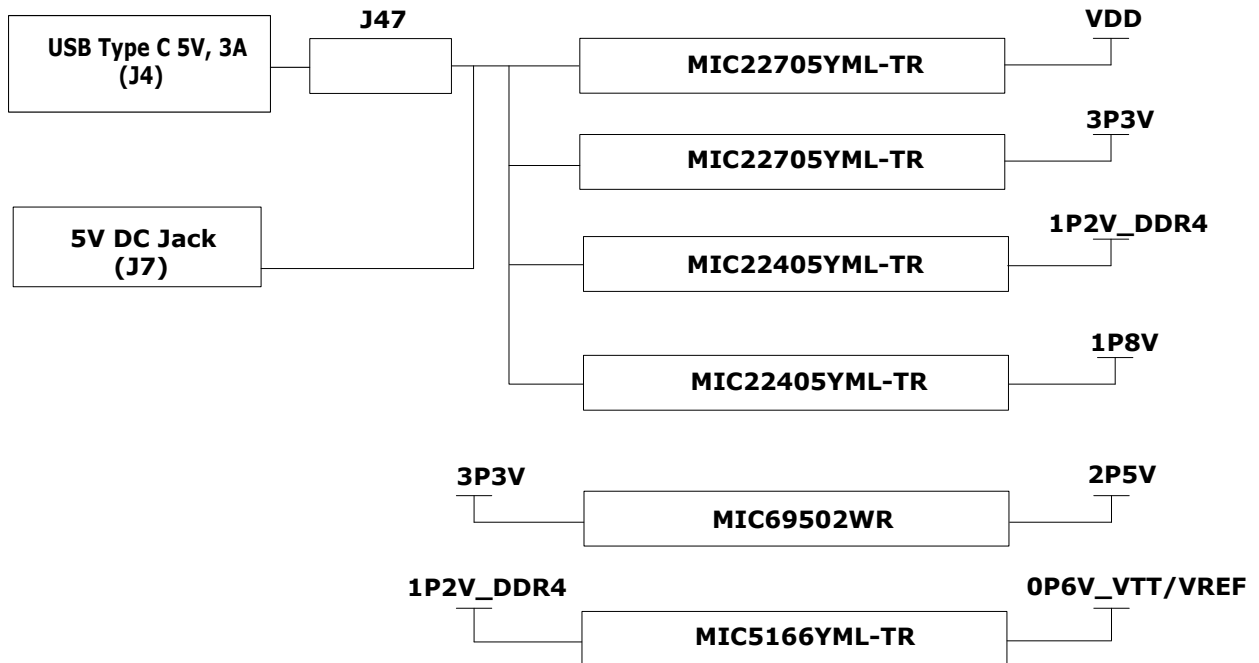

The following table lists the power regulators recommended for the voltage rails on the PIC64GX1000 Curiosity kit.

Table 2.5. Power Regulators

Voltage Rail	Part Number	Description	Current
VDD (1.0V)	MIC22705YML-TR	IC REG BUCK ADJUSTABLE 7A	7A
1P2V_DDR4	MIC22405YML-TR	IC REG BUCK ADJUSTABLE 3A	4A
1P8V	MIC22405YML-TR	IC REG BUCK ADJUSTABLE 3A	4A
2P5V	MIC69502WR	IC REG LINEAR POS ADJ 5A	5A
3P3V	MIC22705YML-TR	IC REG BUCK ADJUSTABLE 7A	7A
VTT/VREF	MIC5166YML-TR	IC PWR SUP 3A HS DDR TERM 10MLF	3A

3. Board Components and Operation

This section describes the key components of the PIC64GX1000 Curiosity kit and provides information about important board operations.

3.1. DDR4 Memory Interface [\(Ask a Question\)](#)

The PIC64GX1000 Curiosity kit has a DDR4 memory connected to Bank 6. The following list provides the DDR4 memory specifications:

- Part number: MT40A512M16TB-062E: R
- Manufacturer: Micron®
- Frequency range: 800 MHz
- Memory size: 1 GB

3.2. microSD Interface [\(Ask a Question\)](#)

The PIC64GX1000 Curiosity kit has a microSD card connected to Bank 4. The following are the microSD card connector specifications:

- Part number: MEM2075-00-140-01-A
- Manufacturer: GCT

The microSD interface is connected using a voltage translator between the SD card connector and silicon.

3.3. Display Interface [\(Ask a Question\)](#)

The PIC64GX1000 Curiosity kit has an HDMI Interface connector. This connector allows the user to view simple overlays and the image from the MIPI camera. This interface supports the HDMI 1.4 data rate.

3.4. Communications Interfaces [\(Ask a Question\)](#)

The PIC64GX1000 Curiosity kit supports the following interfaces for communication:

- Ethernet-SGMII interface: The kit supports a low-power single-port Ethernet 10/100/1000BASE-T PHY device and the part number of the PHY device is VSC8221. The PHY SGMII signals connected to SGMII Bank.
- USB-to-UART interface: The kit supports a USB-to-quad UART bridge controller device, which supports three UART interfaces. The following are the specifications:
 - Part number: FT4232HL
 - Manufacturer: FTDI
 - The UART_B interface is connected to Bank 2
 - UART_C and UART_D are connected to Bank 1



Important: To detect and view the UART COM ports in your **Host PC > Device Manager**, install the [FT4232H drivers](#).

3.5. Expansion Capabilities [\(Ask a Question\)](#)

The PIC64GX1000 Curiosity kit has the following expansion capabilities.

3.5.1. mikroBUS Connector [\(Ask a Question\)](#)

The PIC64GX1000 Curiosity kit has a 16-pin mikroBUS interface connector. It supports interfaces like UART, SPI, and I2C. The mikroBUS signals are connected to Bank 2. For more information on available Click Boards, see [mikroe](#) website.

3.5.2. User IO Connector [\(Ask a Question\)](#)

The PIC64GX1000 Curiosity kit has a 14-pin connector. Through this connector 12 user IOs are interfaced to GPIO Bank 1.

3.6. Debug Circuitry [\(Ask a Question\)](#)

The PIC64GX1000 Curiosity kit is equipped with two push-button switches, four dip switches, and eight debug LEDs. Switches are connected to Bank 1 and Debug LEDs are connected to Bank 2. Three LEDs are for power indication and eight LEDs are for debugging purposes.

The following table lists the debug LED to pin connection.

Table 3.1. Debug LED Connections

LED Number	Pin
LED1	H4
LED2	G5
LED3	G1
LED4	F2
LED5	F4
LED6	E5
LED7	E2
LED8	E1

3.7. Programming Scheme [\(Ask a Question\)](#)

The PIC64GX1000 Curiosity kit supports JTAG programming through an on-board FlashPro5 programmer.

3.8. Form Factor [\(Ask a Question\)](#)

The form factor of the PIC64GX1000 Curiosity kit is 4.145 × 3.595 inches, approximately.

3.9. System Reset [\(Ask a Question\)](#)

RESET_IN# is an input-only reset pad connected to Bank 1. This system reset push-button allows a full reset of the chip to be asserted. The following figure shows a sample reset circuit that uses a Microchip MCP121T-315E/TT device.

Figure 3.1. Reset Circuit



3.10. 50 MHz Oscillator [\(Ask a Question\)](#)

A 50 MHz clock oscillator with an accuracy of ± 10 ppm is available on the PIC64GX1000 Curiosity board. This clock oscillator is connected to the E12 pin to provide a system reference clock as shown in the following figure.

Figure 3.2. 50 MHz Oscillator

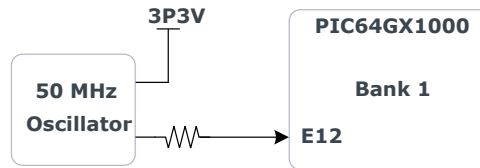

3.11. 125 MHz Oscillator [\(Ask a Question\)](#)

A 125 MHz clock oscillator with an accuracy of ± 10 ppm is available on the PIC64GX1000 Curiosity board. This clock oscillator is connected to the Bank 5 through P5 and P4 pins to provide SGMII reference clock as shown in the following figure.

Figure 3.3. 125 MHz Oscillator

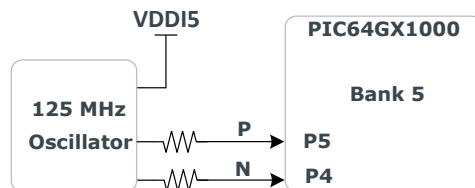

For more information, see the board-level schematics on the [CURIOSITY-PIC64GX1000-KIT](#) page.

3.12. Pin List [\(Ask a Question\)](#)

For more information about all package pins, see *DS50003724, PIC64GX1000 64-bit Microprocessor Datasheet* on the [PIC64GX1000](#) page.

4. Board Components Placement

The following silkscreen shows the top-view of the placement of various components on the board.

Figure 4.1. Silkscreen (Top-View)

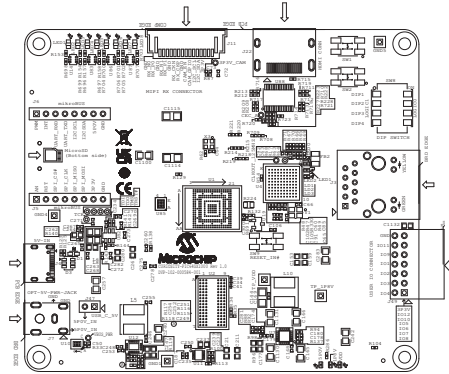

The following silkscreen shows the bottom-view of the placement of various components on the board.

Figure 4.2. Silkscreen (Bottom-View)

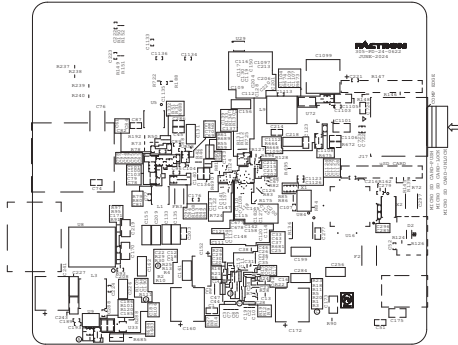

Revision History [\(Ask a Question\)](#)

The revision history describes the changes that were implemented in the document. The changes are listed by revision, starting with the most current publication.

Revision	Date	Description
B	06/2025	Corrected the Embedded Tools VSCode extension in Software and Licensing .
A	07/2024	Initial Revision

Microchip Information

Trademarks

The “Microchip” name and logo, the “M” logo, and other names, logos, and brands are registered and unregistered trademarks of Microchip Technology Incorporated or its affiliates and/or subsidiaries in the United States and/or other countries (“Microchip Trademarks”). Information regarding Microchip Trademarks can be found at <https://www.microchip.com/en-us/about/legal-information/microchip-trademarks>.

ISBN: 979-8-3371-1405-7

Legal Notice

This publication and the information herein may be used only with Microchip products, including to design, test, and integrate Microchip products with your application. Use of this information in any other manner violates these terms. Information regarding device applications is provided only for your convenience and may be superseded by updates. It is your responsibility to ensure that your application meets with your specifications. Contact your local Microchip sales office for additional support or, obtain additional support at www.microchip.com/en-us/support/design-help/client-support-services.

THIS INFORMATION IS PROVIDED BY MICROCHIP “AS IS”. MICROCHIP MAKES NO REPRESENTATIONS OR WARRANTIES OF ANY KIND WHETHER EXPRESS OR IMPLIED, WRITTEN OR ORAL, STATUTORY OR OTHERWISE, RELATED TO THE INFORMATION INCLUDING BUT NOT LIMITED TO ANY IMPLIED WARRANTIES OF NON-INFRINGEMENT, MERCHANTABILITY, AND FITNESS FOR A PARTICULAR PURPOSE, OR WARRANTIES RELATED TO ITS CONDITION, QUALITY, OR PERFORMANCE.

IN NO EVENT WILL MICROCHIP BE LIABLE FOR ANY INDIRECT, SPECIAL, PUNITIVE, INCIDENTAL, OR CONSEQUENTIAL LOSS, DAMAGE, COST, OR EXPENSE OF ANY KIND WHATSOEVER RELATED TO THE INFORMATION OR ITS USE, HOWEVER CAUSED, EVEN IF MICROCHIP HAS BEEN ADVISED OF THE POSSIBILITY OR THE DAMAGES ARE FORESEEABLE. TO THE FULLEST EXTENT ALLOWED BY LAW, MICROCHIP’S TOTAL LIABILITY ON ALL CLAIMS IN ANY WAY RELATED TO THE INFORMATION OR ITS USE WILL NOT EXCEED THE AMOUNT OF FEES, IF ANY, THAT YOU HAVE PAID DIRECTLY TO MICROCHIP FOR THE INFORMATION.

Use of Microchip devices in life support and/or safety applications is entirely at the buyer’s risk, and the buyer agrees to defend, indemnify and hold harmless Microchip from any and all damages, claims, suits, or expenses resulting from such use. No licenses are conveyed, implicitly or otherwise, under any Microchip intellectual property rights unless otherwise stated.

Microchip Devices Code Protection Feature

Note the following details of the code protection feature on Microchip products:

- Microchip products meet the specifications contained in their particular Microchip Data Sheet.
- Microchip believes that its family of products is secure when used in the intended manner, within operating specifications, and under normal conditions.
- Microchip values and aggressively protects its intellectual property rights. Attempts to breach the code protection features of Microchip products are strictly prohibited and may violate the Digital Millennium Copyright Act.
- Neither Microchip nor any other semiconductor manufacturer can guarantee the security of its code. Code protection does not mean that we are guaranteeing the product is “unbreakable”. Code protection is constantly evolving. Microchip is committed to continuously improving the code protection features of our products.